

11 Oak Hill Way

MASTER PERMIT NO. _____

TOWN OF SEWALL'S POINT

Date 12/16/97

BUILDING PERMIT NO. 4304

Building to be erected for PETERS & MESARD Type of Permit _____

Applied for by FREDERICK C MESARD (Contractor) Building Fee 1648-

Subdivision CASTLE HIL Lot 9 Block _____ Radon Fee 19.86

Address 11 OAK HILL WAY Impact Fee 1508²⁰

Type of structure SINGLE FAMILY RES A/C Fee 100

*① Copy of Survey w/
calculations of lot coverage*

Parcel Control Number: _____ Electrical Fee 100

26-37-015.000.00090-50000 Plumbing Fee 100

Amount Paid _____ Check # _____ Cash _____ Other Fees 25% owner (\$12)

Total Construction Cost \$ _____ Roofing Fee 100

TOTAL Fees 3888.06
3988.06

Signed [Signature]
Applicant

Signed [Signature]
Town Building Inspector

Town of Sewall's Point



P.I.N. _____

Date _____

BUILDING PERMIT APPLICATION

to construct:

RESIDENTIAL NEW CONSTRUCTION ADDITION ALTERATION

COMMERCIAL

SQ. FEET _____

DEMOLITION

SQ. FEET _____

NET CHANGE

OTHER: _____ CONTRACT PRICE _____

Owner's Name BONNIE PETERS, FREDERICK C. MEZARD

Owner's Address 2820 SW BRIGHTON WAY, PALM CITY, FL 34990

Fee Simple Titleholder's Name (If other than owner) _____

Fee Simple Titleholder's Address (If other than owner) _____

City _____ State _____ Zip _____

Contractor's Name OWNER/BUILDER

Contractor's Address _____

City _____ State _____ Zip _____

Job Name _____

Job Address OAK HILL WAY, CASTLE HILL

City SEWALL'S POINT County MARTIN

Legal Description LOT 9, CASTLE HILL, PLAT BOOK 12, PAGE 89

Bonding Company N.A.

Bonding Company Address _____

City _____ State _____

Architect/Engineer's Name GARY KELLY

Architect/Engineer's Address 119 W. SIXTH STREET, STUART, FL 34994

Mortgage Lender's Name COMMUNITY SAVINGS

Mortgage Lender's Address 3102 SW MARTIN DOWNS BLVD. PALM CITY, FL 34990

Application is hereby made to obtain a permit to do the work and installations as indicated. I certify that no work or installation has commenced prior to the issuance of a permit and that all work will be performed to meet the standards of all laws regulating construction in this jurisdiction. I understand that a separate permit must be secured for ELECTRICAL WORK, PLUMBING, SIGNS, WELLS, POOLS, FURNACES, BOILERS, HEATERS, TANKS, and AIR CONDITIONERS, etc.

OWNER'S AFFIDAVIT: I certify that all the foregoing information is accurate and that all work will be done in compliance with all applicable laws regulating construction and zoning.

WARNING TO OWNER: YOUR FAILURE TO RECORD A NOTICE OF COMMENCEMENT MAY RESULT IN YOUR PAYING TWICE FOR IMPROVEMENTS TO YOUR PROPERTY.

IF YOU INTEND TO OBTAIN FINANCING, CONSULT WITH YOUR LENDER OR AN ATTORNEY BEFORE RECORDING YOUR NOTICE OF COMMENCEMENT.

[Signature]
Owner or Agent FREDERICK C. MESARD Date 9/3/97

Contractor Date _____

STATE OF FLORIDA
COUNTY OF MARTIN

Sworn to and subscribed before me this 3rd day of September 1997, by Frederick C. Mesard, who: [is/ ~~are~~ personally known to me, ~~or~~ [has/have produced _____ as identification and who did not take an oath.

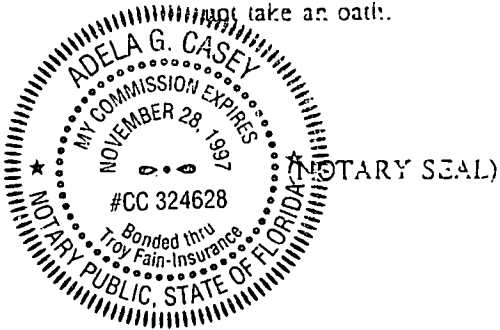

Adela G. Casey
Name: Adela G. Casey
Typed, printed or stamped
I am a Notary Public of the State of Florida having a commission number of CC 324628 and my commission expires: 11-28-97

STATE OF FLORIDA
COUNTY OF MARTIN

Sworn to and subscribed before me this ___ day of _____ 199_, by _____, who: [] is/are personally known to me, or [] has/have produced _____ as identification, and who did not take an oath.

(NOTARY SEAL)

Name: _____
Typed, printed or stamped
I am a Notary Public of the State of Florida having a commission number of _____ and my commission expires: _____

[Signature]
12/16/97
Certificate of Competency Holder

Contractor's State Certification or Registration No. _____

Contractor's Certificate of Competency No. _____

APPLICATION APPROVED BY X _____ Permit Officer

PERMIT GENERAL CONDITIONS

Permit Applications must be accompanied by two (2) sets of the following:

(1) Plans, Sections, and Elevations with wind load and energy calculations signed and sealed by an architect or engineer and including plumbing, mechanical, and electrical drawings and calculations. **Plumbing, Mechanical, and Electrical** (also wells, pools, fences, etc.) require separate applications.

(2) Sketch or survey showing elevations and the locations of existing and proposed improvements, property lines, all setback lines, easements, rights-of-way, and any encroachments.

The permit is valid for twelve (12) months from date of issuance. Renewal of the permit may result in additional requirements and fees prevailing at the time of renewal.

All construction must conform to the Code of Ordinances of the Town of Sewall's Point ("Town Code") and the South Florida Building Code (Dade County 1994 edition, with revisions) ("Building Code"). An approval or permit issued based upon faulty documents or errors and/or omissions by the Building Official does not relieve the owner or the contractor of compliance with the Town Code or the Building Code, nor is it a license to circumvent the Town Code or the Building Code.

A temporary toilet is to be provided for workers or an existing toilet is provided and open to workers.

Debris must be contained in a dumpster-type metal container or must be immediately loaded in a truck (as reroofing may require). Debris will not be allowed to accumulate.

Inspections and permits may be suspended or revoked, work stoppage may be ordered, and other actions may be taken for failure to correct defects, concealing work without inspection, or for willful violations of any of the above conditions or the special conditions, attached, if any.

*NOTE: NOTICE OF COMMENCEMENT required for work with a cumulative value of \$2,500.00 or more.

ATTACHMENTS: _____

ACCEPTED:



Owner

Contractor

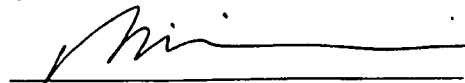

Building Official



OFFICIAL RECEIPT
(FOR MONEY RECEIVED)

No.599314

DATE 12/1, 1997

Finance SCHOOL

RECEIVED FROM Frederick Mesard \$ 1,006.03
(NAME OR ORGANIZATION)

FOR School Impact Fee - Lot 9 Castle Hill

FOR DEPOSIT IN _____ FUND(S)

Lugh Chaffin
PRINCIPAL OR RESPONSIBLE OFFICER

CLERK OF DISTRICT COURT
MARTIN COUNTY, FLORIDA

01190836

Parcel I.D. Number: 26-37-41-015-000-00090-50000
Grantee 1 TIN# _____
Grantee 2 TIN# _____

RECORDED & VERIFIED
BY _____ D.C.

96 AUG 19 PM 1:24

MARSHA STILER

MARTIN COUNTY

CLERK OF DISTRICT COURT

WARRANTY DEED

THIS WARRANTY DEED, made this 15th day of August, 1996,

By: CASTLE HILL ASSOCIATES, INC., a Florida corporation ("Grantor"), whose address is 2363 S. E. Ocean Boulevard, Stuart, Florida 34996,

To: BONNIE PETERS and FREDERICK C. MESARD, as Joint Tenants with Right of Survivorship ("Grantee"), whose address is 2820 S. W. Brighton Way, Palm City, Florida 34990.

WITNESSETH:

THAT GRANTOR, for and in consideration of the sum of Ten (\$10.00) Dollars and other good and valuable considerations to it in hand paid by Grantee, the receipt whereof is hereby acknowledged, by these presents does grant, bargain, sell, alien, remise, release, convey and confirm unto the Grantee and the heirs, executors, administrators, personal representatives, successors and assigns of Grantee, the following real property, situate, lying and being in the County of Martin, State of Florida, particularly described as follows:

Lot 9, CASTLE HILL, according to the Plat thereof, recorded in Plat Book 12, Page 89, Martin County, Florida, public records.

This conveyance is made subject to the following:

1. All of the terms, provisions, covenants, conditions, rights, privileges, obligations, easements and liens set forth and contained in the Declaration of Covenants and Restrictions for Castle Hill, the Articles of Incorporation and By-Laws of Castle Hill



2879 S.W. 42nd Avenue
 Palm City, Florida 34990
 (561) 283-4166
 Fax: (561) 220-1757
 1-800-273-2928

Raised Panel Foamcore

Steel with Foamed Core Garage Doors
 GLAZING OPTIONS



GLAZED 3RD SECTION
 GLAZED TOP SECTION



CATHEDRAL TOP



COLONIAL 3RD SECTION
 COLONIAL TOP SECTION



SHERWOOD TOP - 3 LITE



SUNRAY



SUNBURST TOP

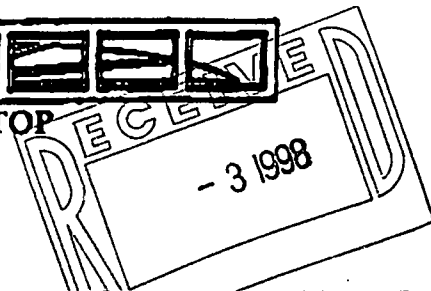

*+ \$100
 for
 install*



PREPARED BY AND RETURN TO:
Town of Sewall's Point
1 S. Sewall's Point Road
Stuart, FL 34996

[Space above this line for recording]

Date: 8-12-98

This is to request a Certificate of Approval for Occupancy to be issued to:
PETERS + MESARD for Permit No. 4304 issued to construct a NEW
HOME upon property described as follows:

Lot 9, Block _____, Section _____, Subdivision CASTLE HILL
known as: 11 OAKHILL WAY When completed in conformance
with the approved plans and approval of the following required inspections.

CERTIFICATE OF OCCUPANCY

TOWN OF SEWALL'S POINT, FLORIDA

Lot Stakes/Setbacks	Approved: <u>2-3-98</u>	Termite Protection	Approved: <u>2-9-98</u>
Footings/Slab	Approved: <u>2-9-98</u>	Rough Plumbing	Approved: <u>2-5-98</u>
Rough Electric	Approved: <u>3-18-98</u>	Lintel/Tie-beam	Approved: <u>3-15-98</u>
Roofing	Approved: <u>5-28-98</u>	Framing/Furring	Approved: <u>3-18-98</u>
Insulation	Approved: <u>7-16-98</u>	HVAC Rough	Approved: <u>7-15-98</u>
Final Electric	Approved: <u>8-12-98</u>	Final Plumbing	Approved: <u>8-12-98</u>
Final HVAC	Approved: <u>8-12-98</u>	Storm Shutters	Approved: <u>8-5-98</u>
Tie-in Survey	Approved: <u>8-10-98</u>	Landscape	Approved: <u>8-12-98</u>

ISSUED THIS 12 DAY OF AUGUST, 1998

Robert Bett

Building Inspector

MASTER PERMIT NO. _____

TOWN OF SEWALL'S POINT

Date 2/28/05

BUILDING PERMIT NO. 7352

Building to be erected for MESARD

Type of Permit FENCE

Applied for by SWART FENCE (Contractor)

Building Fee 30.00

Subdivision CASTLE HILL Lot 9 Block _____

Radon Fee _____

Address 11 OAK HILL WAY

Impact Fee _____

Type of structure SFR

A/C Fee _____

Parcel Control Number:

263741015000000905110000

Electrical Fee _____

Plumbing Fee _____

Roofing Fee _____

Amount Paid 30.00 Check # 3003 Cash _____

Other Fees (_____) _____

Total Construction Cost \$ 1881.00

TOTAL Fees 30.00

Signed Jane Landin
Applicant

Signed Gene Simmons
Town Building Official

PERMIT

- BUILDING
- PLUMBING
- DOCK/BOAT LIFT
- SCREEN ENCLOSURE
- FILL
- TREE REMOVAL

- ELECTRICAL
- ROOFING
- DEMOLITION
- TEMPORARY STRUCTURE
- HURRICANE SHUTTERS
- STEMWALL

- MECHANICAL
- POOL/SPA/DECK
- FENCE
- GAS
- RENOVATION
- ADDITION

INSPECTIONS

- UNDERGROUND PLUMBING _____
- UNDERGROUND MECHANICAL _____
- STEMWALL FOOTING _____
- SLAB _____
- ROOF SHEATHING _____
- TRUSS ENG/WINDOW/DOOR BUCKS _____
- ROOF TIN TAG/METAL _____
- PLUMBING ROUGH-IN _____
- MECHANICAL ROUGH-IN _____
- FRAMING _____
- FINAL PLUMBING _____
- FINAL MECHANICAL _____
- FINAL ROOF _____

- UNDERGROUND GAS _____
- UNDERGROUND ELECTRICAL _____
- FOOTING _____
- TIE BEAM/COLUMNS _____
- WALL SHEATHING _____
- LATH _____
- ROOF-IN-PROGRESS _____
- ELECTRICAL ROUGH-IN _____
- GAS ROUGH-IN _____
- EARLY POWER RELEASE _____
- FINAL ELECTRICAL _____
- FINAL GAS _____
- BUILDING FINAL _____

Town of Sewall's Point
BUILDING PERMIT APPLICATION

Permit Number: _____

OWNER/TITLEHOLDER NAME: FREDERICK MERSARD Phone (Day) 220-3501 (Fax) _____

Job Site Address: 11 Oak Hill Way City: STUART State: FL Zip: 34996

Legal Description of Property: CASTLE HILL, Lot 9 Parcel Number: 26-37-41-015-000-00090-511

Owner Address (if different): _____ City: _____ State: _____ Zip: _____

Description of Work To Be Done: INSTALL 143' of 4' black vinyl chain link fence & gate

WILL OWNER BE THE CONTRACTOR?: Yes No (If no, fill out the Contractor & Subcontractor sections below)

CONTRACTOR/Company: STUART FENCE CO Phone: 288 1151 Fax: 288-3035

Street: PO Box 2636 City: STUART State: FL Zip: 34995

State Registration Number: _____ State Certification Number: _____ Martin County License Number: CFE 3584

COST AND VALUES: Estimated Cost of Construction or Improvements: \$ 1881.⁰⁰ (Notice of Commencement needed over \$2500)

SUBCONTRACTOR INFORMATION:

Electrical: _____ State: _____ License Number: _____
Mechanical: _____ State: _____ License Number: _____
Plumbing: _____ State: _____ License Number: _____
Roofing: _____ State: _____ License Number: _____

ARCHITECT _____
Street: _____ Phone Number: _____
City: _____ State: _____ Zip: _____

ENGINEER _____
Street: _____ Phone Number: _____
City: _____ State: _____ Zip: _____

AREA SQUARE FOOTAGE - SEWER - ELECTRIC Living: _____ Garage: _____ Covered Patios: _____ Screened Porch: _____
Carport: _____ Total Under Roof _____ Wood Deck: _____ Accessory Building: _____

I understand that a separate permit from the Town may be required for ELECTRICAL, PLUMBING, MECHANICAL, SIGNS, POOLS, WELLS, FURNACE, BOILERS, HEATERS, TANKS DOCKS, SEA WALLS, ACCESSORY BUILDING, SAND OR FILL ADDITION OR REMOVAL, AND TREE REMOVAL AND RELOCATIONS.

CODE EDITIONS IN EFFECT AT TIME OF APPLICATION: National Electrical Code: 2002 Florida Building Code (Structural, Mechanical, Plumbing, Gas): 2001 Florida Energy Code: 2001 Florida Accessibility Code: 2001

I HEREBY CERTIFY THAT THE INFORMATION I HAVE FURNISHED ON THIS APPLICATION IS TRUE AND CORRECT TO THE BEST OF MY KNOWLEDGE AND I AGREE TO COMPLY WITH ALL APPLICABLE CODES, LAWS AND ORDINANCES DURING THE BUILDING PROCESS.

OWNER OR AGENT'S SIGNATURE (required) [Signature] M263-243-46-248-0

State of Florida, County of: MARTIN
This the 24 day of Feb, 2005
by FREDERICK MERSARD who is personally known to me or produced DL

as identification. [Signature] Janis L. Loudin
Notary Public # DD119654
Expires May 21, 2006
Bonded thru Atlantic Bonding Co., Inc.

My Commission Expires: _____

CONTRACTOR SIGNATURE (required) _____

On State of Florida, County of: _____
This the _____ day of _____, 200____
by _____ who is personally known to me or produced _____

As identification. _____
Notary Public

My Commission Expires: _____ Seal

FILE COPY
TOWN OF SEWALL'S POINT
 THESE PLANS HAVE BEEN
 REVIEWED FOR CODE COMPLIANCE
 DATE: 4/29/05

BUILDING OFFICIAL
 Gene Simmons

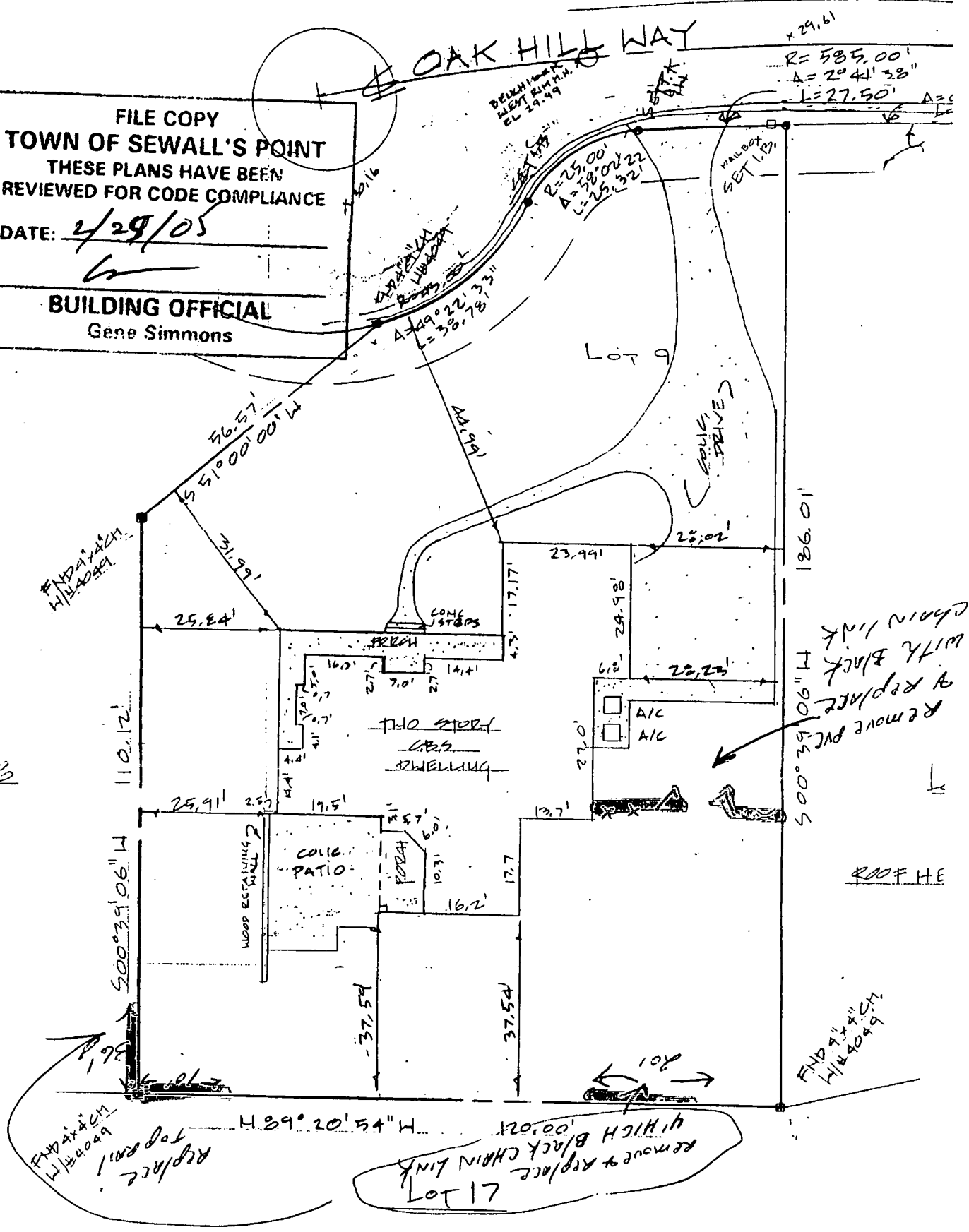

1. PROPERTY LOCATED WITHIN FLOOD ZONE: "C"
2. PROPERTY ADDRESS: 11 OAK HILL WAY
3. CERTIFIED TO: **BONNIE PETERS & FREDERICK C. MESARD**
 ROBERT A. BURSON P.A. ATTORNEYS

NOTES:

1. Survey of description as furnished
2. Lands shown hereon were no and/or rights-of-way of record (P) Denotes distance or bearing (F) Denotes measured distance (C) Denotes calculated distance or

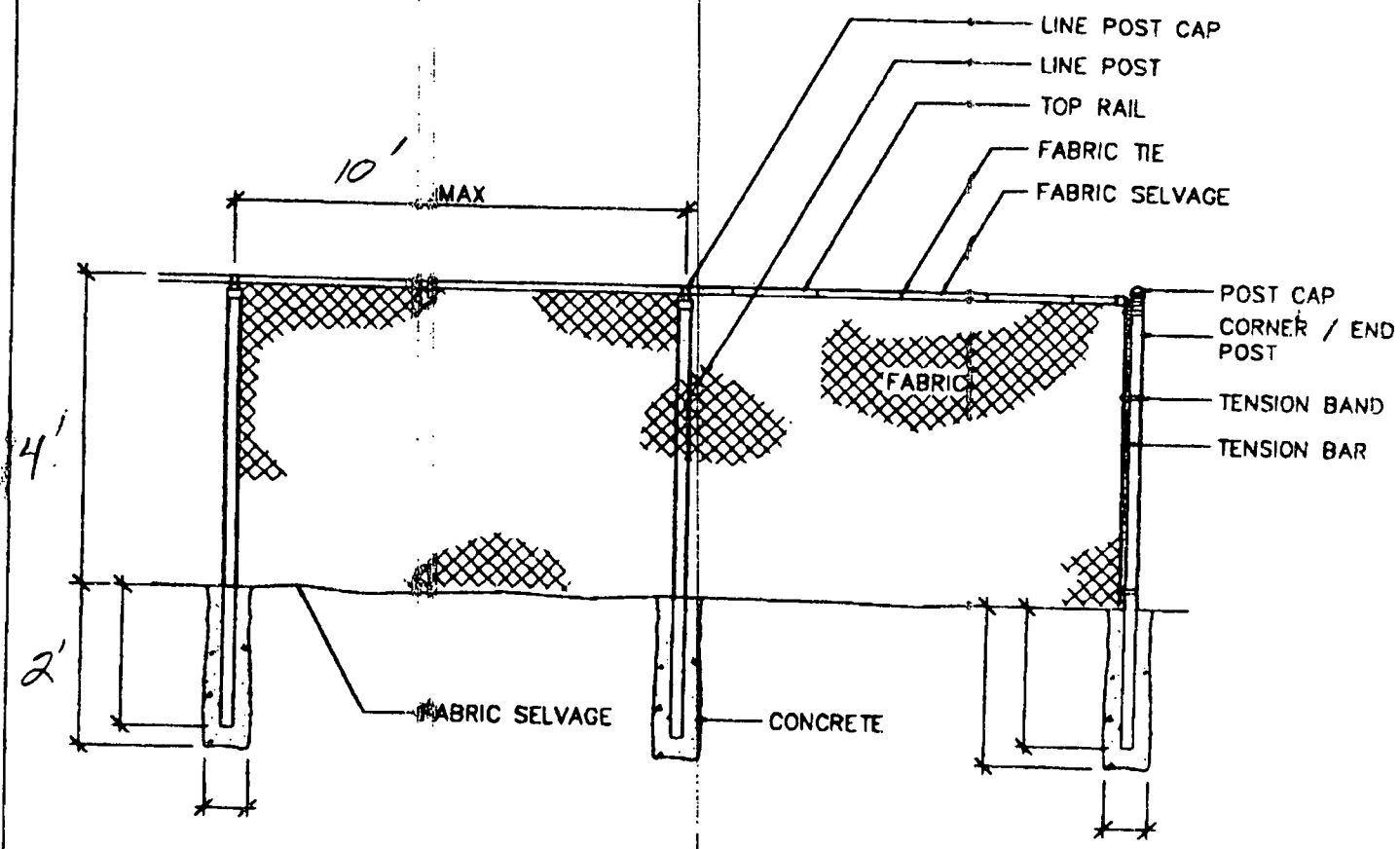



CHAIN LINK FENCING DETAIL
BLACK VINYL

TOWN OF SEWALL'S POINT

Building Department - Inspection Log

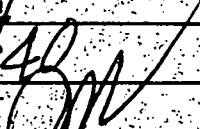
Date of Inspection: Mon Wed Fri 4/22, 2005 Page 2 of

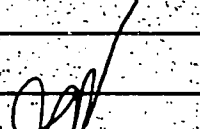
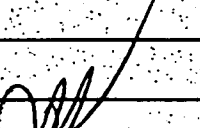
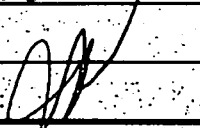
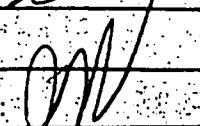
PERMIT	OWNER/ADDRESS/CONTR.	INSPECTION TYPE	RESULTS	NOTES/COMMENTS
736	ELWOOD	Final	PASS	CLOSE
2	15 MIDDLE RD ALPHA ZETA			INSPECTOR: 
7485	ENGLE	Dry-IN	FAIL	
4	14 PALM ROAD PHOENIX COMETA			INSPECTOR:  \$42
7262	HB ASSOC - SABOUEIN	Elec Wall Part	PASS	
21	3760 SE OCEAN KIRCHMAN	FRAMING MECHANICAL	PASS PASS	INSPECTOR: 
TREE	CONROY	TREE	PASS	
8	126 S. Sewalls			INSPECTOR: 
7195	THOMPSON	FRAMING	PASS	
6	179 S. RIVER R FLORIDA'S FINEST			INSPECTOR: 
71352	MESSEARD	FENCE FINAL	PASS	CLOSE
20	11 OAK HILL WAY STUART FENCE			INSPECTOR: 
7446	MACCALLUM	FINAL GARAGE	PASS	CLOSE
19	3 QUAIL RUN LA PROTEN GARAGE	loop		INSPECTOR: 

OTHER: _____

10457

SHUTTERS



TOWN OF SEWALL'S POINT BUILDING DEPARTMENT
 One S. Sewall's Point Road
 Sewall's Point, Florida 34996
 Tel 772-287-2455 Fax 772-220-4765

BUILDING PERMIT CARD

THIS CARD MUST BE POSTED IN A CONSPICUOUS PLACE IN PLAIN VIEW FROM THE STREET PRIOR TO BEGINNING ANY WORK

A FINAL INSPECTION IS REQUIRED FOR ALL PERMITS

PERMIT NUMBER:	10475	DATE ISSUED:	JUNE 6, 2013
SCOPE OF WORK:	2 SHUTTERS		
CONTRACTOR:	ADVANCED HURRICANE PROTECTION		
PARCEL CONTROL NUMBER:	263741015-000-000905	SUBDIVISION	CASTLE HILL - LOT 9
CONSTRUCTION ADDRESS:	11 OAK HILL WAY		
OWNER NAME:	BURNS		
QUALIFIER:	JOHN ZERVOPOULOS	CONTACT PHONE NUMBER:	220-1200

WARNING TO OWNER: YOUR FAILURE TO RECORD A NOTICE OF COMMENCEMENT MAY RESULT IN YOUR PAYING TWICE FOR IMPROVEMENTS TO YOUR PROPERTY. IF YOU INTEND TO OBTAIN FINANCING, CONSULT WITH YOUR LENDER OR AN ATTORNEY BEFORE RECORDING YOUR NOTICE OF COMMENCEMENT. A CERTIFIED COPY OF THE RECORDED NOTICE OF COMMENCEMENT MUST BE SUBMITTED TO THE BUILDING DEPARTMENT PRIOR TO THE FIRST REQUESTED INSPECTION.

NOTICE: IN ADDITION TO THE REQUIREMENTS OF THIS PERMIT, THERE MAY BE ADDITIONAL RESTRICTIONS APPLICABLE TO THIS PROPERTY THAT MAY BE FOUND IN PUBLIC RECORDS OF THIS COUNTY, AND THERE MAY BE ADDITIONAL PERMITS REQUIRED FROM OTHER GOVERNMENTAL ENTITIES SUCH AS WATER MANAGEMENT DISTRICTS, STATE AGENCIES, OR FEDERAL AGENCIES.

24 HOUR NOTICE REQUIRED FOR INSPECTIONS - ALL CONSTRUCTION DOCUMENTS MUST BE AVAILABLE ON SITE
 CALL 287-2455 - 8:00AM TO 4:00PM INSPECTIONS: 9:00AM TO 3:00PM - MONDAY THROUGH FRIDAY

INSPECTIONS

UNDERGROUND PLUMBING	_____	UNDERGROUND GAS	_____
UNDERGROUND MECHANICAL	_____	UNDERGROUND ELECTRICAL	_____
STEM-WALL FOOTING	_____	FOOTING	_____
SLAB	_____	TIE BEAM/COLUMNS	_____
ROOF SHEATHING	_____	WALL SHEATHING	_____
TIE DOWN/TRUSS ENG	_____	INSULATION	_____
WINDOW/DOOR BUCKS	_____	LATH	_____
ROOF DRY-IN/METAL	_____	ROOF TILE IN-PROGRESS	_____
PLUMBING ROUGH-IN	_____	ELECTRICAL ROUGH-IN	_____
MECHANICAL ROUGH-IN	_____	GAS ROUGH-IN	_____
FRAMING	_____	METER FINAL	_____
FINAL PLUMBING	_____	FINAL ELECTRICAL	_____
FINAL MECHANICAL	_____	FINAL GAS	_____
FINAL ROOF	_____	BUILDING FINAL	_____

ALL RE-INSPECTION FEES AND ADDITIONAL INSPECTION REQUESTS WILL BE CHARGED TO THE PERMIT HOLDER. THE CONTRACTOR OR OWNER /BUILDER MUST SCHEDULE A FINAL INSPECTION. FAILURE TO RECEIVE A SUCCESSFUL FINAL INSPECTION WILL RESULT IN PERMIT RENEWAL FEES, FINES, AND OR DENIAL OF FUTURE BUILDING PERMITS TO THE CONTRACTOR OR OWNER /BUILDER.

**Town of Sewall's Point
BUILDING PERMIT APPLICATION**

Permit Number: 10475

Date: 5/22/13

OWNER/LESSEE NAME: Robert Burns Phone (Day) 812-4304 (Fax) _____
 Job Site Address: 11 Oak Hill wly City: Sewall Pt State: FL Zip: _____
 Legal Description _____ Parcel Control Number: _____
 Fee Simple Holder Name: _____ Address: _____
 City: _____ State: _____ Zip: _____ Telephone: _____

***SCOPE OF WORK (PLEASE BE SPECIFIC):** Install hurricane shutters on 2 windows

WILL OWNER BE THE CONTRACTOR?
 (If yes, Owner Builder questionnaire must accompany application)
 YES _____ NO
Has a Zoning Variance ever been granted on this property?
 YES _____ (YEAR) _____ NO
 (Must include a copy of all variance approvals with application)

COST AND VALUES: (Required on ALL permit applications)
 Estimated Value of Improvements: \$ 1,800.00
 (Notice of Commencement required when over \$2500 prior to first inspection, \$7,500 on HVAC change out)
 Is subject property located in flood hazard area? VE10 AE9 AE8
FOR ADDITIONS, REMODELS AND RE-ROOF APPLICATIONS ONLY:
 Estimated Fair Market Value prior to improvement: \$ _____
 (Fair Market Value of the Primary Structure only, Minus the land value)
 PRIVATE APPRAISALS MUST BE SUBMITTED WITH PERMIT APPLICATION

Construction Company: Advanced Hurricane Protection Phone: 230-1200 Fax: _____
 Qualifiers name: John Zervopoulos Street: 4517 SIE Commu Nc City: Stait State: FL Zip: _____
 State License Number: CBC 1259339 OR: Municipality: _____ License Number: _____

LOCAL CONTACT: John Zervopoulos
 DESIGN PROFESSIONAL: _____
 Street: _____ City: _____
 Phone Number: _____

RECEIVED
 MAY 29 2013
 Fla. License # _____
 State _____ Zip: _____

AREAS SQUARE FOOTAGE: Living: _____ Garage: _____ Covered Patios/ Porches: _____ Enclosed Storage: _____
 Carport: _____ Total under Roof _____ Elevated Deck _____ Enclosed area below BFE* _____
 * Enclosed non-habitable areas below the Base Flood Elevation greater than 300 sq ft require Flood Conversion Covenant Agreement.

CODE EDITIONS IN EFFECT THIS APPLICATION: Florida Building Code (Structural, Mechanical, Plumbing, Existing, Gas): 2010
 National Electrical Code: 2008, Florida Energy Code: 2010, Florida Accessibility Code: 2010, Florida Fire Prevention Code: 2010

- WARNINGS TO OWNERS AND CONTRACTORS:**
- YOUR FAILURE TO RECORD A NOTICE OF COMMENCEMENT MAY RESULT IN YOUR PAYING TWICE FOR IMPROVEMENTS TO YOUR PROPERTY. WHEN FINANCING, CONSULT WITH YOUR LENDER OR AN ATTORNEY BEFORE RECORDING YOUR NOTICE OF COMMENCEMENT. A NOTICE OF COMMENCEMENT MUST BE RECORDED AND POSTED ON THE JOB SITE BEFORE THE FIRST INSPECTION.
 - IT IS YOUR RESPONSIBILITY TO DETERMINE IF YOUR PROPERTY IS ENCUMBERED BY ANY DEED RESTRICTIONS. SOME RESTRICTIONS APPLICABLE TO THIS PROPERTY MAY BE FOUND IN THE PUBLIC RECORDS OF MARTIN COUNTY OR THE TOWN OF SEWALL'S POINT. THERE MAY BE ADDITIONAL PERMITS REQUIRED FROM OTHER GOVERNMENTAL ENTITIES SUCH AS WATER MANAGEMENT DISTRICTS, STATE AGENCIES, OR FEDERAL AGENCIES.
 - BUILDING PERMITS FOR SINGLE FAMILY RESIDENCES AND SUBSTANTIAL IMPROVEMENTS TO SINGLE FAMILY RESIDENCES ARE VALID FOR A PERIOD OF 24 MONTHS. RENEWAL FEES WILL BE ASSESSED AFTER 24 MONTHS PER TOWN ORDINANCE 50-95.
 - THIS PERMIT WILL BECOME NULL AND VOID IF THE WORK AUTHORIZED BY THIS PERMIT IS NOT COMMENCED WITHIN 180 DAYS, OR IF WORK IS SUSPENDED OR ABANDONED FOR A PERIOD OF 180 DAYS AT ANY TIME AFTER THE WORK IS COMMENCED. ADDITIONAL FEES WILL BE ASSESSED ON ANY PERMIT THAT BECOMES NULL AND VOID. REF. FBC 2007 SECT. 105.4.1, 105.4.1.1 - .5.

***** A FINAL INSPECTION IS REQUIRED ON ALL BUILDING PERMITS *****

AFFIDAVIT: APPLICATION IS HEREBY MADE TO OBTAIN A PERMIT TO DO THE WORK AS SPECIFICALLY INDICATED ABOVE. I CERTIFY THAT NO WORK OR INSTALLATION HAS COMMENCED PRIOR TO THE ISSUANCE OF A PERMIT AND THAT THE INFORMATION I HAVE FURNISHED ON THIS APPLICATION IS TRUE AND CORRECT TO THE BEST OF MY KNOWLEDGE. I AGREE TO COMPLY WITH ALL APPLICABLE CODES, LAWS, AND ORDINANCES OF THE TOWN OF SEWALL'S POINT DURING THE BUILDING PROCESS.

OWNER / AGENT / LESSEE - NOTARIZED SIGNATURE:
 X _____
 State of Florida, County of: Martin
 On This the 4 day of June, 2013
 by Robert C. Burns who is personally
 known to me or produced FDL# B652-763-57-
 As identification. 287-0

 Notary Public

CONTRACTOR / LICENSEE NOTARIZED SIGNATURE:
 X _____
 State of Florida, County of: Martin
 On This the 29 day of May, 2013
 by John Zervopoulos
 known to me or produced FDL# 2611-460-81-331-0
 As identification. _____

 Notary Public

SINGLE FAMILY PERMIT APPLICATIONS MUST BE ISSUED WITHIN 30 DAYS OF APPROVAL NOTIFICATION (FBC 105.3.4) ALL OTHER APPLICATIONS WILL BE CONSIDERED ABANDONED AFTER 180 DAYS (FBC 105.3.2) - PLEASE PICK UP YOUR PERMIT PROMPTLY!



TOWN OF SEWALL'S POINT BUILDING DEPARTMENT
 One S. Sewall's Point Road
 Sewall's Point, Florida 34996
 Tel 772-287-2455 Fax 772-220-4765

BUILDING PERMIT RECEIPT

PERMIT NUMBER:	10475
ADDRESS	11 OAK HILL WAY - BURNS
DATE 6/6/13	SCOPE OF WORK 2 SHUTTERS

SINGLE FAMILY OR ADDITION /REMODEL	Declared Value	\$	
Plan Submittal Fee (\$350.00 SFR, \$175.00 Remodel < \$200K) (No plan submittal fee when value is less than \$100,000)		\$	
Total square feet air-conditioned space: (@ \$121.75 per sq. ft.)		s.f.	
Total square feet non-conditioned space, or interior remodel: (@ \$59.81 per sq. ft.)		s.f.	
Total square feet remodel with new trusses: @ \$90.78 per sq. ft.		\$	
Total Construction Value:		\$	
Building fee: (2% of construction value SFR or >\$200K)		\$	
Building fee: (1% of construction value < \$200K + \$100 per insp.)			
Total number of inspections (Value < \$200K)@\$100ea		\$	
Dept. of Comm. Affairs Fee: (1.5% of permit fee - \$2.00,min)		\$	
DBPR Licensing Fee: (1.5% of permit fee - \$2.00 min.)		\$	
Road impact assessment: (.04% of construction value - \$5.00 min.)			
Martin County Impact Fee:		\$	
TOTAL BUILDING PERMIT FEE:		\$	

ACCESSORY PERMIT	Declared Value:	\$	
Total number of inspections @ \$100.00 each			100
Dept. of Comm. Affairs Fee: (1.5% of permit fee - \$2.00 min)		\$	2
DBPR Licensing Fee: (1.5% of permit fee - \$2.00 min.)		\$	2
Road impact assessment: (.04% of construction value - \$5.00 min.)		\$	5
TOTAL ACCESSORY PERMIT FEE:		\$	109

Handwritten signature
 Cash
 (100)

Martin County, Florida Laurel Kelly, C.F.A

generated on 5/29/2013 10:23:01 AM EDT

Summary

Parcel ID	Account #	Unit Address	Market Total Value	Website Updated
26-37-41-015-000-00090-5	4153	11 OAK HILL WY, SEWALL'S POINT	\$534,020	5/25/2013

Owner Information

Owner(Current)	BURNS ROBERT C SHANAHAN-BURNS CHRISTINA A
Owner/Mail Address	11 OAK HILL WAY STUART FL 34996
Sale Date	2/17/2012
Document Book/Page	2561 2768
Document No.	2317669
Sale Price	665000

Location/Description

Account #	4153	Map Page No.	SP-01
Tax District	2200	Legal Description	CASTLE HILL, LOT 9 PI# 26-37-41-015-000-00090- 50000
Parcel Address	11 OAK HILL WY, SEWALL'S POINT		
Acres	.4300		

Parcel Type

Use Code	0100 Single Family
Neighborhood	120900 Sewall's Lndg/Castle Hill

Assessment Information

Market Land Value	\$225,000
Market Improvement Value	\$309,020
Market Total Value	\$534,020



TOWN OF SEWALL'S POINT BUILDING DEPARTMENT
One S. Sewall's Point Road
Sewall's Point, Florida 34996
Tel 772-287-2455 Fax 772-2204765

HURRICANE SHUTTER INSTALLATION CHECKLIST

A document review will be performed on the following items prior to the submittal of a permit application. Failure to submit these items will result in the application package returned to the applicant until the deficient documents are included. This review sheet must accompany the application submittal.

Please make sure you have ALL required copies before submitting permit application

- ~~1 Copy Completed Permit application~~
- ~~2 Copies Shutter schedule~~
- 2 Copies Floor plan sketch showing the location and ID number of each shutter.
MUST MATCH SHUTTER SCHEDULE.
- 2 Copies Shutter engineering specifications complying with the 2010 FBC
- 1 Copy Prior to the final inspection; an impact installation affidavit must be submitted.



TOWN OF SEWALL'S POINT BUILDING DEPARTMENT
 One S. Sewall's Point Road
 Sewall's Point, Florida 34996
 Tel 772-287-2455 Fax 772-2204765

SHUTTER SCHEDULE

I.D. NO.	APPOX OPENING SIZE (WXH)	APPOX SHUTTER WIDTH	APPOX HEIGHT	# OF STORM BARS REQ'D	ANCHOR SPACING	# OF WINDOW BARS EACH SIDE	HEADER REINT. REQ'D YES/NO	REMARKS
	37"X63"	45"	71"	N/A	12"	N/A	NO	EXAMPLE
1	72 X 36	79	41	NA	6"			
2	36 X 18	42	22	NA	6"			
3	72 X 36	79	41	NA	6"			
4	36 X 18	42	22	NA	6"			
5								
6								
7								
8								
9								
10								
11								
12								
13								
14								
15								
16								
17								
18								
19								
20								
21								
22								
23								
24								
25								

TOWN OF SEWALL'S POINT
 BUILDING DEPARTMENT
 FILE COPY

	Width	Height	SqFt
1	_____	X _____	_____
2	_____	X _____	_____
3	_____	X _____	_____
4	_____	X _____	_____
5	_____	X _____	_____
6	_____	X _____	_____
7	_____	X _____	_____
8	_____	X _____	_____
9	_____	X _____	_____
10	_____	X _____	_____
11	_____	X _____	_____
12	_____	X _____	_____
13	_____	X _____	_____
14	_____	X _____	_____
15	_____	X _____	_____
16	_____	X _____	_____
17	_____	X _____	_____
18	_____	X _____	_____
19	_____	X _____	_____
20	_____	X _____	_____
21	_____	X _____	_____
22	_____	X _____	_____
23	_____	X _____	_____
24	_____	X _____	_____
25	_____	X _____	_____
26	_____	X _____	_____
27	_____	X _____	_____
28	_____	X _____	_____

Client Name: Burns
 Address: _____
 Phone: _____
 Shutter Type: _____
 Other Work _____

Sheet 1 of 1

Date: 5/20/13

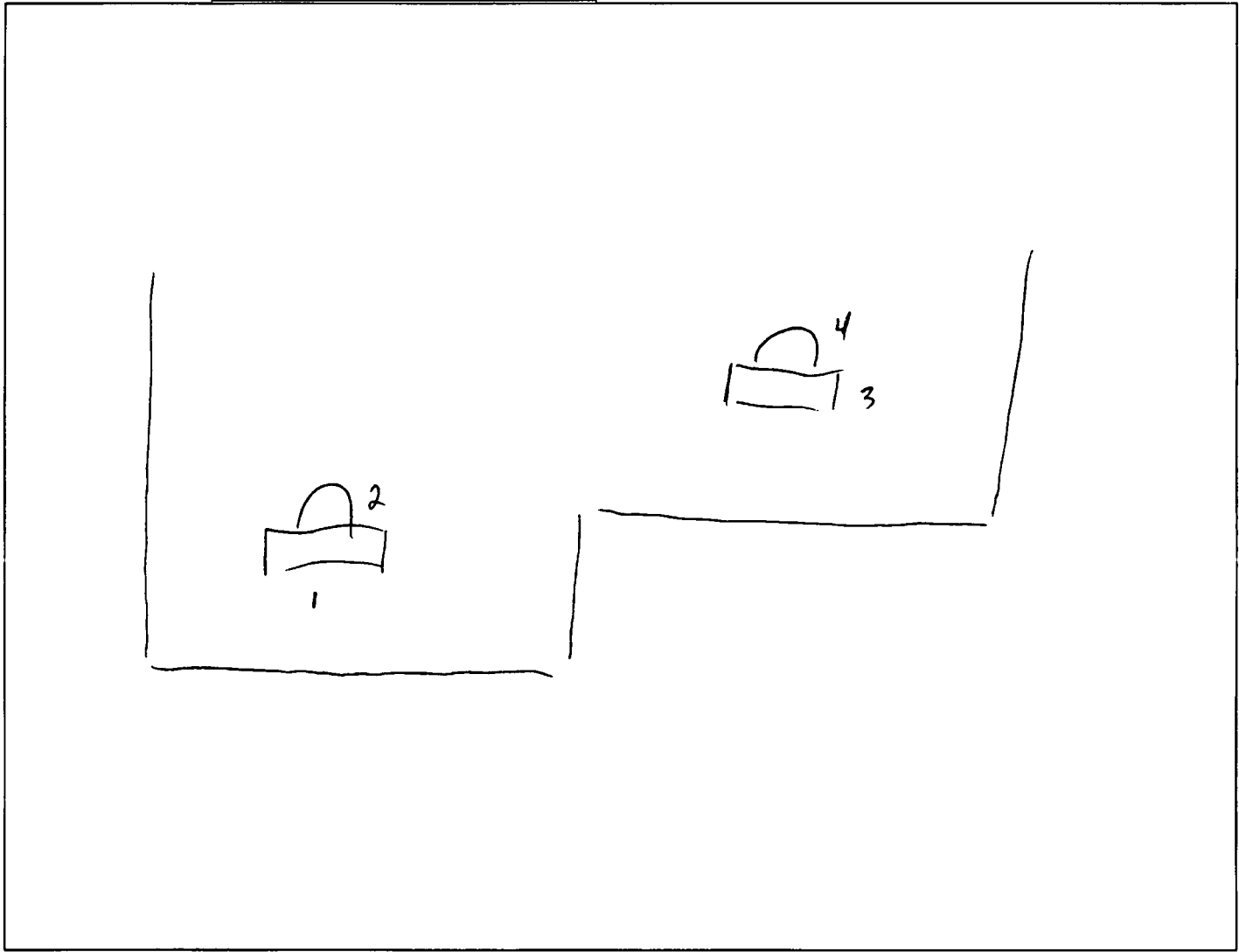

TOTAL



[Agriculture](#) |
 [Commerce](#) |
 [Health Services](#) |
 [Transportation](#)

Florida Department of
Business & Professional Regulation

[BCIS Home](#) |
 [Log In](#) |
 [User Registration](#) |
 [Hot Topics](#) |
 [Submit Surcharge](#) |
 [Stats & Facts](#) |
 [Publications](#) |
 [FBC Staff](#) |
 [BCIS Site Map](#) |
 [Links](#) |
 [Search](#)



[Product Approval Menu](#) >
 [Product or Application Search](#) >
 [Application List](#) >
 Application Detail

License efficiently. Regulate fairly.



FL #	FL13779-R2														
Application Type	Revision														
Code Version	2010														
Application Status	Approved														
Comments															
Archived	<input type="checkbox"/>														
Product Manufacturer	Crimsafe North America														
Address/Phone/Email	Suite 1-3 3020 Reynolds Rd Lakeland, FL 33840-2440 (863) 510-0188 mhess@crimsafe.com														
Authorized Signature	Mark Hess mhess@crimsafe.com														
Technical Representative															
Address/Phone/Email															
Quality Assurance Representative															
Address/Phone/Email															
Category	Shutters														
Subcategory	Storm Panels														
Compliance Method	Evaluation Report from a Florida Registered Architect or a Licensed Florida Professional Engineer <input checked="" type="checkbox"/> Evaluation Report - Hardcopy Received														
Florida Engineer or Architect Name who developed the Evaluation Report	Robert L. Clark														
Florida License	PE-39712														
Quality Assurance Entity	Architectural Testing, Inc.														
Quality Assurance Contract Expiration Date	12/31/2014														
Validated By	William D. Robertson <input checked="" type="checkbox"/> Validation Checklist - Hardcopy Received														
Certificate of Independence	FL13779_R2_COI_Fixed_Buildout_prod_eval_11222011.pdf														
Referenced Standard and Year (of Standard)	<table border="0"> <thead> <tr> <th><u>Standard</u></th> <th><u>Year</u></th> </tr> </thead> <tbody> <tr> <td>ASTM E 1886</td> <td>2006</td> </tr> <tr> <td>ASTM E 1996</td> <td>2006</td> </tr> <tr> <td>ASTM E 330</td> <td>2002</td> </tr> <tr> <td>TAS 201</td> <td>1994</td> </tr> <tr> <td>TAS 202</td> <td>1994</td> </tr> <tr> <td>TAS 203</td> <td>1994</td> </tr> </tbody> </table>	<u>Standard</u>	<u>Year</u>	ASTM E 1886	2006	ASTM E 1996	2006	ASTM E 330	2002	TAS 201	1994	TAS 202	1994	TAS 203	1994
<u>Standard</u>	<u>Year</u>														
ASTM E 1886	2006														
ASTM E 1996	2006														
ASTM E 330	2002														
TAS 201	1994														
TAS 202	1994														
TAS 203	1994														
Equivalence of Product Standards Certified By															
Sections from the Code															

Product Approval Method Method 1 Option D

Date Submitted 02/23/2012
 Date Validated 06/25/2012
 Date Pending FBC Approval 06/27/2012
 Date Approved 08/07/2012

Summary of Products		
FL #	Model, Number or Name	Description
13779.1	Fixed Build-Out Hurricane Screen	Aluminum Fixed Build-Out hurricane screen with Stainless steel mesh
Limits of Use Approved for use in HVHZ: Yes Approved for use outside HVHZ: Yes Impact Resistant: Yes Design Pressure: +75.0/-75.0 Other: Overall size tested 53" wide by 85" high		Installation Instructions FL13779_R2_II_FBC_Fixed_Build-out_05172012.pdf Verified By: Architectural Testing, Inc Created by Independent Third Party: Yes Evaluation Reports FL13779_R2_AE_Fixed_Buildout_prod_eval_11222011.pdf Created by Independent Third Party: Yes



Contact Us :: [1940 North Monroe Street, Tallahassee FL 32399](#) Phone: 850-487-1824

The State of Florida is an AA/EEO employer. [Copyright 2007-2010 State of Florida](#). :: [Privacy Statement](#) :: [Accessibility Statement](#) :: [Refund Statement](#)

Under Florida law, email addresses are public records. If you do not want your e-mail address released in response to a public-records request, do not send electronic mail to this entity. Instead, contact the office by phone or by traditional mail. If you have any questions, please contact 850.487.1395. *Pursuant to Section 455.275 (1), Florida Statutes, effective October 1, 2012, licensees licensed under Chapter 455, F.S. must provide the Department with an email address if they have one. The emails provided may be used for official communication with the licensee. However email addresses are public record. If you do not wish to supply a personal address, please provide the Department with an email address which can be made available to the public. To determine if you are a licensee under Chapter 455, F.S., please click [here](#).

Product Approval Accepts:



BUILD OUT WINDOW HURRICANE SCREEN

FLORIDA BUILDING CODE TESTING

BY

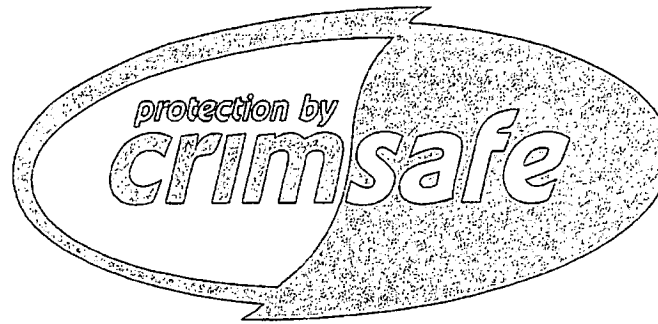

Crimsafe North America
PO Box 2440 Eaton Park
FL 33840-2440
Phone: +1 863 510 0188
Fax: +1 863 665 0485

R. J. Olan
9/16/12
39712

BUILD-OUT WINDOW HURRICANE SCREEN

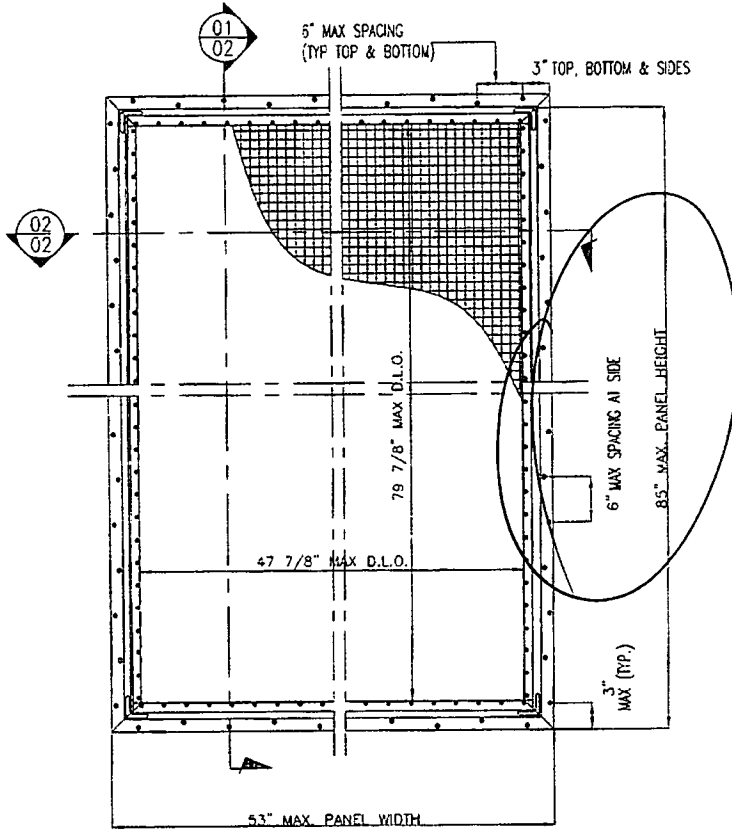

01
01 TYPICAL ELEVATION
SCALE EXTER ELEV

MAXIMUM ALLOWABLE DESIGN PRESSURES:

+75.0 PSF
-75.0 PSF

MIN SEPERATION FROM GLAZING:

HVHZ	3"
NON-HVHZ	1.575"

GENERAL NOTES :

1. THE WINDOW SCREEN SYSTEM DESCRIBED HEREIN HAS BEEN DESIGNED AND TESTED IN COMPLIANCE WITH THE 2010 FLORIDA BUILDING CODE WITH AND TEST PROTOCOLS TAS 201, 202 & 203. THIS SYSTEM MAY BE USED WITHIN THE HIGH VELOCITY HURRICANE ZONE (HVHZ) AS WELL AS THROUGHOUT THE STATE OF FLORIDA.
2. POSITIVE AND NEGATIVE DESIGN PRESSURES SHALL BE CALCULATED IN ACCORDANCE WITH THE GOVERNING CODE.
3. INSTALLATION OF ALL UNITS SHALL ALLOW FOR RESPECTIVE MINIMUM SEPERATION FROM GLAZING AS NOTED ON THIS PAGE. REF SECTION DETAILS FOR DESCRIPTION OF THIS DISTANCE.
4. MULTIPLE UNITS SHALL BE INSTALLED USING APPROVED ALUMINUM STRUCTURAL FRAME OF ALLOY 6063-T5(MIN). FRAME SHALL MEET ALL APPLICABLE IMPACT & WINDLOAD CRITERIA, AND SHALL BE INSTALLED PER RESPECTIVE PRODUCT APPROVAL DOCUMENTATION.
5. THE SYSTEM DETAILED HEREIN IS GENERIC AND DOES NOT PROVIDE INFORMATION FOR A SPECIFIC SITE. FOR SITE CONDITIONS DEFFERENT FROM THE CONDITIONS DETAILED HEREIN, A PROFESSIONAL ENGINEER OR REGISTERED ARCHITECT SHALL PREPARE SITE SPECIFIC DOCUMENTS.
6. PERMIT HOLDER SHALL VERIFY THE ADEQUACY OF THE EXISTING STRUCTURE TO WITHSTAND SUPERIMPOSED LOADS.
7. PERIMETER SQUARE TUBE MAY BE ANCHORED TO VERTICAL FACE("FACE MOUNT") OF HOST STRUCTURE.
8. SYSTEM MAY BE INSTALLED VERTICALLY OR HORIZONTALLY (AS SHOWN IN THIS PAGE).

SYSTEM NOTES :

1. FRAME & PANEL CONSTRUCTION: EXTRUDED ALUMINUM FRAME CORNERS ARE MITERED, AND SCREWED.
2. FRAME DOES NOT CONTAIN ANY HARDWARE.
3. MESH CONSTRUCTION: STAINLESS STEEL GRADE MESH IS MADE UP OF 304 "HIGH TENSILE" STAINLESS STEEL WITH ϕ 0.035" STRANDS ARRANGED 10 STRANDS BY 10 STRANDS PER SQUARE INCH THE MESH INFORMATION IS DESCRIBED IN SHEET 3.
4. THE MESH IS ATTACHED ONTO THE MAIN FRAME BY A REMOVABLE ALUMINUM CLAMP WITH TAMPER RESISTANT SECURITY HEAD SCREW.

Manufacturer:



Crimsafe North America
PO Box 2440 Eaton Park
FL 33840-2440
Phone: +1 863 510 0188
Fax: +1 863 665 0485

Product:

BUILD OUT WINDOW HURRICANE SCREEN

Engineering:

R. J. Allen
5/16/12
39712

Rev.	Rev. Description
25/1/12	Changed wording on General notes 1.
10/4/12	Changed dimension on section

Date: 24 Sep 2010
Scale: NA
Design by: CRIMS SAFE

PRODUCT CONTROL DIVISION

Drawing Number
MD-500-BOW

Sheet
1 of 4

ALL DIMENSION IN INCHES

Manufacturer:



Crimsafe North America
 PO Box 2440 Eaton Park
 FL 33840-2440
 Phone: +1 863 510 0188
 Fax: +1 863 665 0485

Product:

**BUILD OUT WINDOW
 HURRICANE SCREEN**

Engineering:

E. J. [Signature]
 5/16/12
 #29712

Rev.	Rev. Description
00/4/12	Changed screw value as anchor table

Date: 24 Sep 2010
 Scale: NA
 Design by: CRIMS SAFE

PRODUCT CONTROL DIVISION

Drawing Number
 MD-500-BOW

Sheet
 2 of 4

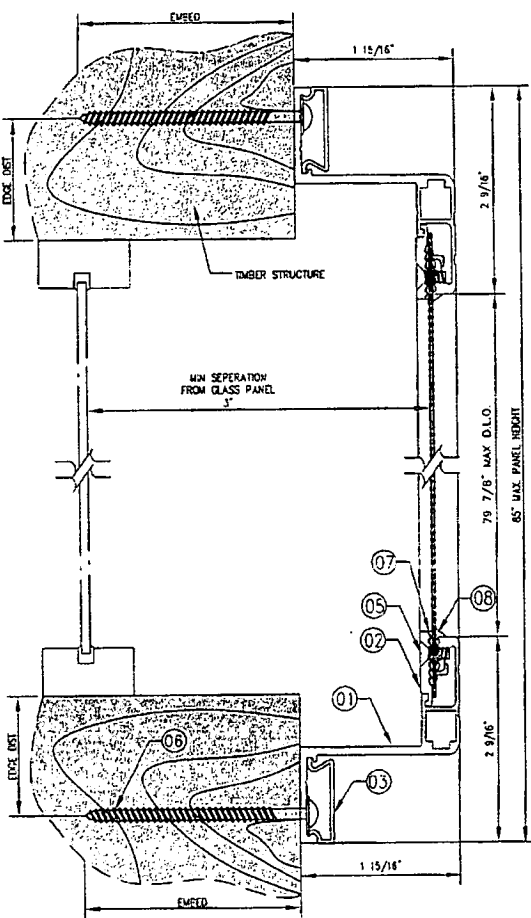

ATTACHMENT TO WOOD

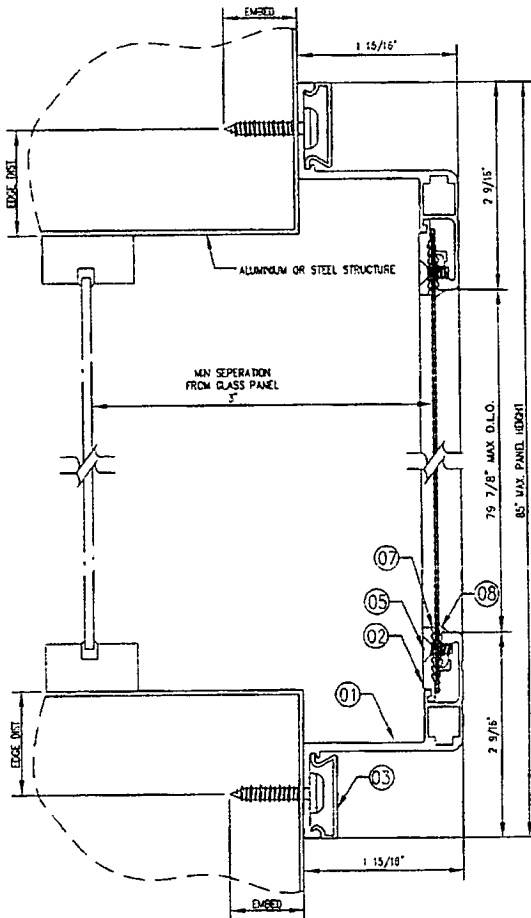

ATTACHMENT TO ALUMINIUM OR STEEL

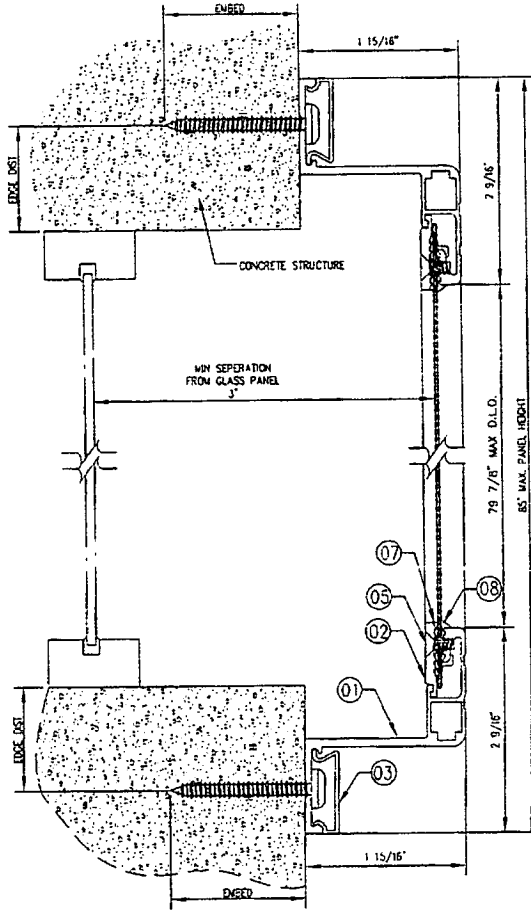

ATTACHMENT TO HOLLOW
 BLOCK OR CONCRETE

- 01 VERTICAL CROSS SECTION
- 02 SIDE FIX HURRICANE WINDOW

ANCHOR TABLE:

TYPE	STRUCTURE	MIN. EMBED.
3/8"	CONCRETE OR HOLLOW BLOCK WITH MIN. EDGE DISTANCE 2". WITH SCREW SPACING OF 6"	1 3/8"
#12 Self-Drilling Sheet Metal Screws	ALUMINUM OR STEEL FRAMING WITH MIN. WALL THICKNESS OF 1/8" AND EDGE DISTANCE 1/2". WITH SCREW SPACING OF 6"	1/8"
#10	WOOD /TIMBER WITH MIN. EDGE DISTANCE 1/2". WITH SCREW SPACING OF 5"	3/8"

Installation shown is for wood frame, concrete, CMU, aluminum and steel tubes as similar.

ALL DIMENSION IN INCHES

Manufacturer:



Crimsafe North America
 PO Box 2440 Eaton Park
 FL 33840-2440
 Phone: +1 863 510 0188
 Fax: +1 863 665 0485

Product:

**BUILD OUT WINDOW
 HURRICANE SCREEN**

Engineering:

[Handwritten signature]
 5/16/12
 #59711

Rev.	Rev. Description
10/4/12	Changed some value on anchor table and dimension changed on section

Date: 24 Sep 2010
 Scale: NA
 Design by: CRIMS SAFE

PRODUCT CONTROL DIVISION

Drawing Number
 MD-500-BOW

Sheet
 3 of 4

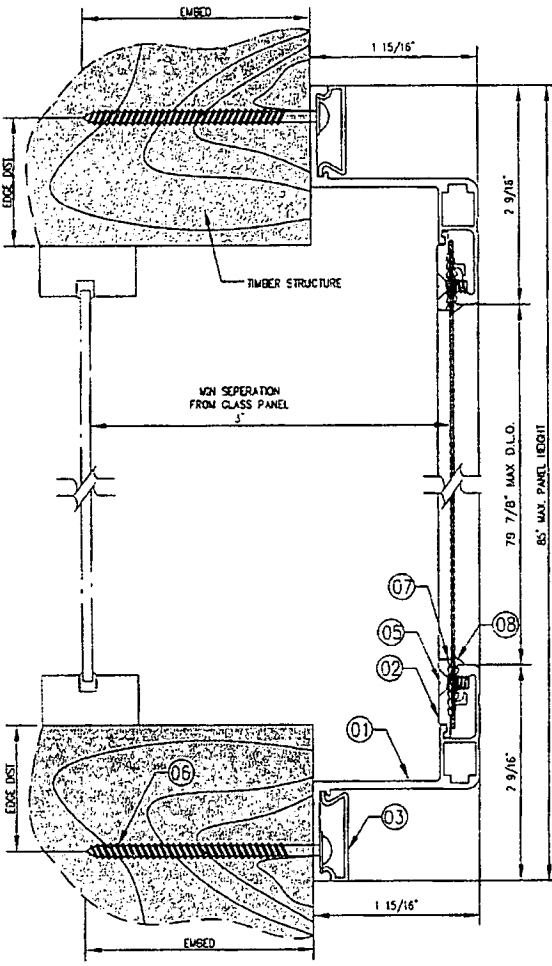

01 VERTICAL CROSS SECTION
 02 SIDE FIX HURRICANE WINDOW

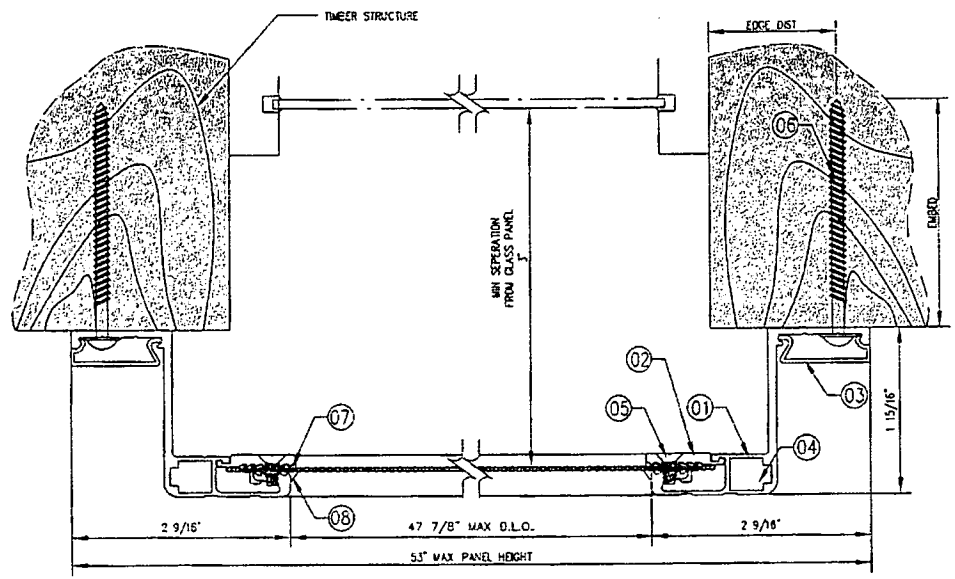

02 HORIZONTAL CROSS SECTION
 02 SIDE FIX HURRICANE WINDOW

ANCHOR TABLE:

TYPE	STRUCTURE	MIN EMBD.
3/16"	CONCRETE OR HOLLOW BLOCK WITH MIN EDGE DISTANCE 2" WITH SCREEN SPACING OF 6"	1 3/8"
#10 Self Drilling Sheet Metal Screws	ALUMINUM OR STEEL FRAMING WITH MIN WALL THICKNESS OF 1/8" AND EDGE DISTANCE 1/2" WITH SCREEN SPACING OF 6"	1/8"
#10	WOOD /TIMBER WITH MIN EDGE DISTANCE 1/2" WITH SCREEN SPACING OF 6"	1 3/8"

Installation shown is for wood frame, concrete, CMU, aluminum and steel tubes as similar.

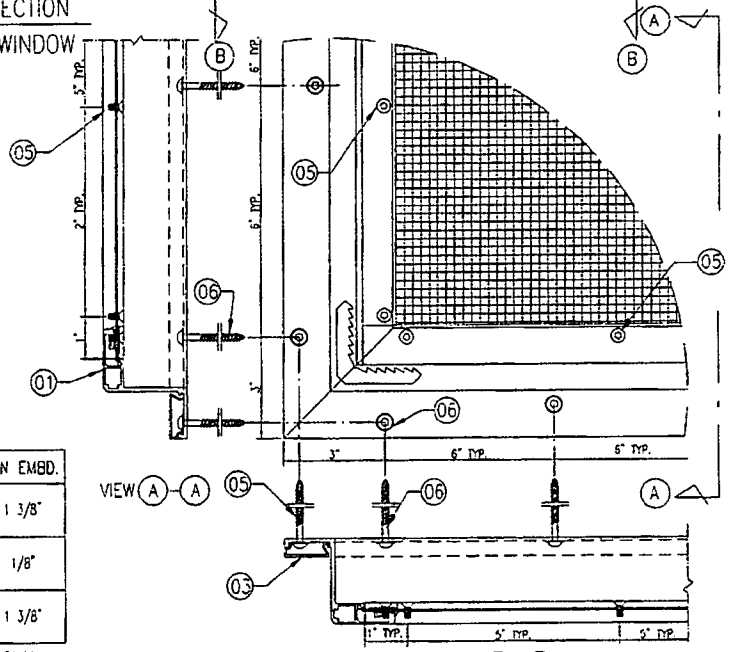

VIEW A-A
 VIEW B-B ALL DIMENSION IN INCHES

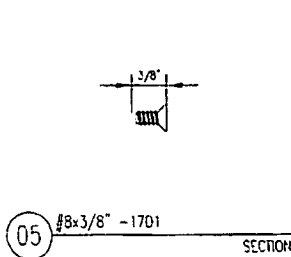
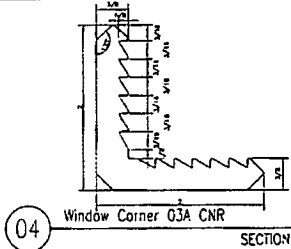
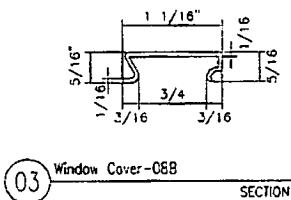
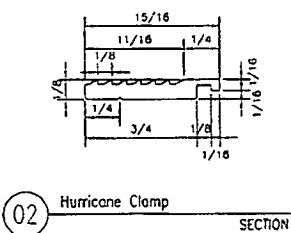
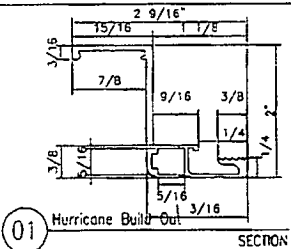

BILL OF MATERIAL			
ITEM	DESCRIPTION	MATERIAL	QTY
01	Hurricane Build Out	6063-T5	4
02	Hurricane Clamp	6063-T5	4
03	Window Cover-OBB	6063-T5	4
04	Window Corner O3A CNR	6063-T5	4
05	#8x3/8" -1701	STAINLESS STEEL	50
06	#10 X 2 3/4" -170	STAINLESS STEEL	45
07	Tesa Tape	-	4
08	Santoprene Insulator	Santoprene	4

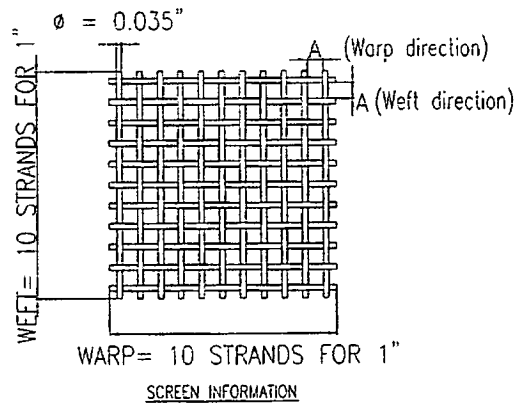
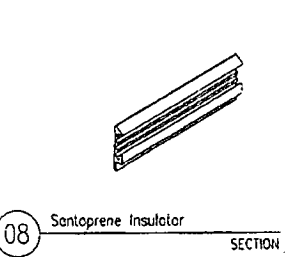
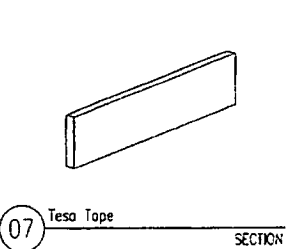
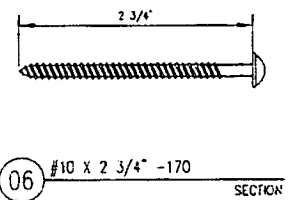

ANCHOR NOTES:

1. ALLOWABLE ANCHORS SHALL BE AS LISTED IN APPROPRIATE ANCHOR SCHEDULE AND SPACED SHOWN ON SHEET 1 ELEVATIONS.
2. ANCHORS SHALL BE INSTALLED IN ACCORDANCE WITH MANUFACTURER'S RECOMMENDATIONS. MINIMUM EMBEDMENT DEPTHS AND EDGE DISTANCES SHALL APPLY AS NOTED IN APPROVALS
3. SYSTEM MAY BE INSTALLED TO CONCRETE, HOLLOW BLOCK, WOOD, STEEL, OR AN APPROVED IMPACT RESISTANT ALUMINUM FRAME OF ALLOY 6063-T5 (MIN). FRAME SHALL BE INSTALLED PER RESPECTIVE
4. WHERE EXISTING STRUCTURE IS WOOD FRAMING, EXISTING CONDITIONS MAY VARY. FIELD VERIFY THAT FASTENERS ARE INTO ADEQUATE WOOD FRAMING MEMBERS, NOT PLYWOOD.
5. WHERE WOOD SCREWS FASTEN TO NARROW FACE OF STUD FRAMING, FASTENER SHALL BE LOCATED IN CENTER OF NOMINAL (MIN) WOOD STUD (3/4\"/>

ALL DIMENSION IN INCHES

Manufacturer:

Crimsafe North America
 PO Box 2440 Eaton Park
 FL 33840-2440
 Phone: +1 863 510 0188
 Fax: +1 863 665 0485

Product:
BUILD OUT WINDOW HURRICANE SCREEN

Engineering:

Rev.	Rev. Description

Date: 19 March 2010
 Scale: NA
 Design by: CRIMS SAFE

PRODUCT CONTROL DIVISION

Drawing Number
 MD-500-BOW

Sheet
 4 of 4



TOWN OF SEWALL'S POINT BUILDING DEPARTMENT
 One S. Sewall's Point Road
 Sewall's Point, Florida 34996
 Tel 772-287-2455 Fax 772-2204765

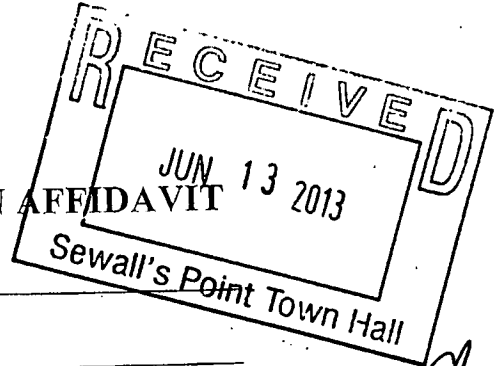

IMPACT PROTECTION INSTALLATION AFFIDAVIT

BLDG. PERMIT NUMBER: 10475
 JOB SITE ADDRESS: 11 Oak Hill Way
 CONTRACTOR/OWNER: Advanced Hurricane Protection
 PHONE NUMBER: 220-1200
 QUALIFIER NAME: John Zervopoulos
 LICENSE NUMBER: CBC 1259339

Out of FWP

I John Zervopoulos, do hereby affirm:

Owner or Contractor - Please print name
 The following impact protection was used as per the 2010 FBC 1609.1.4 for all exterior glazed openings at the above referenced job site.

- Impact Resistant Glass
- Approved Shutters

That I personally observed the complete installation of all hurricane panel/shutters on the above referenced project and further affirm that they are fitted properly for the openings they are intended to protect.

Signature of Owner or Contractor: [Signature] Date: 6/13/13

Sworn to and subscribed before me this 13 Day of June 2013
 By John Zervopoulos
Valerie Camlet
 Notary Public, State of Florida Notary Seal/Stamp



Personally known to me _____
 Produced ID _____
 Type FWD# 2611-460-81-3310

Sewall' Point Building Department will inspect the structural attachment of the panel rails and/or the shutter assembly attachment to the building, per the manufacturer's product approvals, ASCE 7 and the 2010 Florida Building code at final inspection.

TOWN OF SEWALLS POINT

BUILDING DEPARTMENT - INSPECTION LOG

Date of Inspection Mon Tue Wed Thur Fri 6-17-13 Page 1 of 1

PERMIT #	OWNER/ADDRESS/CONTRACTOR	INSPECTION TYPE	RESULTS	COMMENTS
10415	Smith 11 Palmetto Ark Homes	Window buck	Pass	INSPECTOR <i>[Signature]</i>
10415	Burns	Final	Pass	INSPECTOR <i>[Signature]</i>
	1102 2nd Way Advanced Hurricane	Shutters	Pass	INSPECTOR <i>[Signature]</i>
10398	Luger 9 Riverview Schiller	Pool electric	Pass	INSPECTOR <i>[Signature]</i>
10471	Campbell 1 Oakwood Dr A Quality Const	Final Pool Encl.	Pass	Close INSPECTOR <i>[Signature]</i>
10314	Fitch 3 Timor St Seagate	rough electric + rough plumbing Kitchen laundry	Pass	INSPECTOR <i>[Signature]</i>
10440	Puchalski 60 Banyan Rd Freedom Home	tie beam/ column	Fail	No FOOTER INSP called Brad INSPECTOR <i>[Signature]</i>
10451	Bellingham 2 Via de Cristo Solar Energy	Final solar electric all outside open cats.	Pass	Close INSPECTOR

BUILDING PERMIT

FORM BOARD SURVEY DATE 2/3/98
COMPACTION TESTS DATE _____
GROUND ROUGH DATE 2/5/98
SOIL POISONING DATE 2/9/98
FOOTINGS / PIERS DATE 2/9/98
SLAB ON GRADE DATE 2/9/98
TIE-BEAMS & COLUMNS DATE 3/15/98
STRAPS AND ANCHORS DATE 4/14/98
DRIVEWAY DATE 8/10-98
AS-BUILT SURVEY DATE 8-10-98

SHEATHING DATE 3/18/98
FRAMING DATE 3/18/98
INSULATION DATE 4/16/98
ROOF DRY-IN DATE 5/28/98
ROOF FINAL DATE 8-12-98
METER FINAL DATE 8-12-98
AS BUILT SURVEY DATE 8-10-98
STORM PANELS DATE 8-5-98
LANDCAPE & GRADE DATE 8-12-98
FINAL INSPECTION DATE 8-12-98

MESARD
A304

FLOOD ZONE _____

LOWEST HABITABLE FLOOR ELEV. _____

24 HOURS NOTICE REQUIRED FOR INSPECTIONS.

CALL 287-2455

WORK HOURS – 8:00 AM UNTIL 5:00 PM

MONDAY TROUGH SATURDAY

New Construction Remodel Addition Demolition

MASTER PERMIT NO. _____

TOWN OF SEWALL'S POINT

Date 12/16/97

BUILDING PERMIT NO. 4304

Building to be erected for PETERS & MESARD Type of Permit _____

Applied for by FREDERICK C MESARD (Contractor) Building Fee 1648-

Subdivision CASTLE HIL Lot 9 Block _____ Radon Fee 17.⁸⁶

Address 11 OAK HILL WAY Impact Fee 1508²⁰

Type of structure SINGLE FAMILY RES A/C Fee 100

*① Copy of Survey w/
calculations of lot coverage*

Parcel Control Number: _____ Electrical Fee 100

26-37-015.000.00090-50000 Plumbing Fee 100

Amount Paid _____ Check # _____ Cash _____ Other Fees (owner build) 412

Total Construction Cost \$ _____ Roofing Fee 100

TOTAL Fees 3888.06

3988.06

Signed *[Signature]* _____

Applicant

Signed *[Signature]* _____

Town Building Inspector