

103 North Sewall's Point Road

5199

DOCK

MASTER PERMIT NO. N/A

TOWN OF SEWALL'S POINT

Date 12/11/00

BUILDING PERMIT NO. 5199

Building to be erected for HENRY M. ROTHBERG

Type of Permit DOCK

Applied for by CUSTOM BUILT MARINE CONST (Contractor)

Building Fee \$240.00

Subdivision _____ Lot _____ Block _____

Radon Fee _____

Address 103 N SEWALL'S POINT RD.

Impact Fee _____

Type of structure S.F.R

A/C Fee _____

Parcel Control Number

Electrical Fee _____

35-38-41-000-000-0012

Plumbing Fee _____

Amount Paid \$240.00

Check # 14865 Cash _____

Roofing Fee _____

Total Construction Cost \$ 50,000.00

Other Fees (_____)

TOTAL Fees \$240.00

Signed [Signature]
Applicant

Signed [Signature]
Town Building Inspector OFFICIAL

DOCK PERMIT

INSPECTIONS

SETBACKS
PILINGS
BOAT LIFT

DATE _____
DATE _____
DATE _____

WATER
ELECTRIC
DECK
FINAL

DATE _____
DATE _____
DATE _____
DATE 12/26/01

24 HOURS NOTICE REQUIRED FOR INSPECTIONS.

CALL 287-2455

WORK HOURS - 8:00 AM UNTIL 5:00 PM

MONDAY THROUGH SATURDAY

New Construction **Remodel** **Addition** **Demolition**

This permit must be visible from the street, accessible to the inspector.

**FURTHER CONDITIONS ARE SET FORTH IN THE APPLICATION FOR PERMIT,
NOTATIONS ON THE APPROVED SUBMITTALS, AND ATTACHMENTS IN THE PERMIT FILE.**

DO NOT FASTEN THIS OR ANY OTHER SIGN TO A TREE!



**Town of Sewall's Point
BUILDING PERMIT APPLICATION**

Bldg -Permut Number

0002 0 1 100
2000

Owner or Titleholder's Name Henry M Rothberg Phone No. (304) 998-4659
 Street: 103 N Sewalls Point Rd City Sewalls Point State: FL Zip 34996
 Legal Description of Property: Section 35, Twp 37 S, Range 41 E Martin Co

Parcel Number: 35-37 4A 000 000 0013

Location of Job Site: Same / to construct 24x8 terminal, total 995sf.
 TYPE OF WORK TO BE DONE: Remove bathroom + platform, Reduce width of access

CONTRACTOR/Company Name Custom Built Marine Const Phone No. (701) 288 4254
 Street: 3170 SE WAALER ST City STUART State FL Zip 34997
 State Registration _____ State License: SPO1118

ARCHITECT Custom Built Marine Construction, Inc Phone No. () _____
 Street: 3170 SE WAALER ST. City STUART State FL Zip 34997

ENGINEER: JACK WEBBER Phone No () 229-2722
 Street _____ City STUART State FL Zip _____

AREA SQUARE FOOTAGE - SEWER - ELECTRIC

Living Area _____ Garage Area _____ Carport _____ Accessory Bldg _____
 Covered Patio _____ Scr Porch _____ Wood Deck 995 sf Dock _____
 Type Sewage: _____ Septic Tank Permit # from Health Dept. _____
 New Electrical Service Size: _____ AMPS

FLOOD HAZARD INFORMATION

Flood zone _____ Minimum Base Flood Elevation (BFE) _____ NGVD
 Proposed first habitable floor finished elevation _____ NGVD (minimum 1 foot above BFE)

COSTS AND VALUES

Estimated cost of construction or Improvement: \$50,000
 Estimated Fair Market Value (FMV) prior to improvement: \$ _____
 If Improvement, is cost greater than 50% of Fair Market Value? YES _____ NO _____
 Method of determining Fair Market Value _____

SUBCONTRACTOR INFORMATION: (Notification to this office of subcontractor change is mandatory.)

Electrical _____ State _____ License # _____
 Mechanical _____ State _____ License # _____
 Plumbing: _____ State _____ License # _____
 Roofing _____ State _____ License # _____

Application is hereby made to obtain a permit to do the work and installations as indicated I certify that no work or installation has commenced prior to the issuance of a permit and that all work will be performed to meet the standard of all laws regulating construction in this jurisdiction I understand that a separate permit from the Town may be required for ELECTRICAL, PLUMBING, SIGNS, WELLS, POOLS, FURNACES, BOILERS, HEATERS, TANKS, AIR CONDITIONERS, DOCKS, SEA WALLS, ACCESSORY BUILDINGS, SAND OR FILL ADDITION OR REMOVAL, AND TREE REMOVAL.

I HEREBY CERTIFY. THAT THE INFORMATION I HAVE FURNISHED ON THIS APPLICATION IS TRUE AND CORRECT TO THE 'BEST OF MY KNOWLEDGE AND I AGREE TO COMPLY WITH ALL APPLICABLE CODES, LAWS AND ORDINANCES DURING THE BUILDING PROCESS, INCLUDING FLORIDA MODEL ENERGY CODES

OWNER or AGENT SIGNATURE (Required)
Murray Barz
 Owner
 State of Florida, County of: MARTIN On this the 4 day of Oct, 2000, by _____ who is personally known to me or produced _____ as identification.
Margy Barz
 Notary Public
 My Commission Expires: 5-15-04

CONTRACTOR SIGNATURE (Required)
DAVID CORRIGAN
 Contractor
 State of Florida, County of MARTIN On this the 4 day of Oct, 2000, by _____ who is personally known to me or produced _____ as identification.
Margy Barz
 Notary Public
 My Commission Expires: 5-15-04

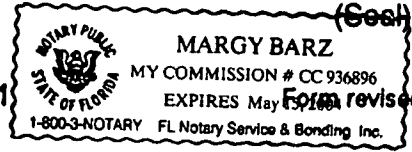

TREE REMOVAL (Attach sealed survey)

Number of trees to be removed: _____ Number of trees to be retained _____ Number of trees to be planted: _____ Number of Specimen trees removed: _____
Fee: \$ _____ Authorized/Date: _____

DEVELOPMENT ORDER # _____

1. ALL APPLICATIONS REQUIRE

- a. Property Appraisers Parcel Number.
- b. Legal Description of your property. (Can be found on your deed survey or Tax Bill.)
- c. Contractors name, address, phone number & license numbers
- d. Name all sub-contractors (properly licensed).
- e. Current Survey

2. Take completed application to the Permits and Inspections Office for approval. Provide construction details and a plot plan(s) showing setbacks, yard coverage, parking and position of all buildings on the property, stormwater retention plan, etc. Compliance with subdivision regulations can also be determined at this time

3. Take the application showing Zoning approval (complete with plans & plot plan) to the Health Department for septic tank. Attach the pink copy to the building application

4. Return all forms to the Permits and Inspection Office. All planned construction requires: two (2) sets of plans, drawn to scale with engineer's or architects seal and the following items.

- a. Floor Plan
- b. Foundation Details
- c. Elevation Views - Elevation Certificate due after slab inspection,
- d. Plot Plan (show desired floor elevation relative to Sea Level in front of building, plus location of driveway).
- e. Truss layout
- f. Vertical Wall Sections (one detail for each wall that is different)
- g. Fireplace drawing: If prefabricated submit manufacturers data

ADDITIONAL Required Documents are:

- 1. Use permit (for driveway connection to public Right of Way). Return form with plot plan showing driveway location (State Road A-1-A East Ocean Boulevard only)
- 2. Well Permit or information on existing well & pump
- 3. Flood Hazard Elevation (if applicable).
- 4. Energy Code Compliance Certification plus any Approved Forms and/or Energy Code Compliance Sheets
- 5. Statement of Fact (for Homeowner Builder), and proof of ownership (Deed or Tax receipt).
- 6. Irrigation Sprinkler System layout showing location of heads, valves, etc.
- 7. A certified copy of the Notice of Commencement must be filed in this office and posted at the job site prior to the first inspection
- 8. Replat required upon completion of slab or footing inspection And Prior to any further inspections.

NOTICE: In addition to the requirements of this permit, there may be additional restrictions applicable to this property that may be found in the public records of COUNTY OF MARTIN, and there may be additional permits required from other governmental entities such as water management districts, state and federal agencies

Approved by Building Official _____ Date: _____

Approved by Town Engineer _____ Date: _____
(If required)

COPY

ACORD. CERTIFICATE OF LIABILITY INSURANCE DATE (MM/DD/YY) 12/12/00

PRODUCER
WORKERS' COMP SPECIALISTS, INC
P.O. BOX 810909
BOCA RATON, FL 33481-0909

THIS CERTIFICATE IS ISSUED AS A MATTER OF INFORMATION ONLY AND CONFERS NO RIGHTS UPON THE CERTIFICATE HOLDER. THIS CERTIFICATE DOES NOT AMEND, EXTEND OR ALTER THE COVERAGE AFFORDED BY THE POLICIES BELOW.

INSURED
CUSTOM-BUILT MARINE CONSTRUCTION, INC.
3170 SE WAALER STREET
STUART, FL 34997

COMPANIES AFFORDING COVERAGE

COMPANY A	GREAT AMERICAN INSURANCE COMPANY
COMPANY B	RECEIVED
COMPANY C	
COMPANY D	

FILE
lectin
Wrent
FILE

COVERAGE
THIS IS TO CERTIFY THAT THE POLICIES OF INSURANCE LISTED BELOW HAVE BEEN ISSUED TO THE INSURED NAMED ABOVE FOR THE POLICY PERIOD INDICATED, NOTWITHSTANDING ANY REQUIREMENT, TERM OR CONDITION OF ANY CONTRACT OR OTHER DOCUMENT WITH RESPECT TO WHICH THIS CERTIFICATE MAY BE ISSUED OR MAY PERTAIN, THE INSURANCE AFFORDED BY THE POLICIES DESCRIBED HEREIN IS SUBJECT TO ALL THE TERMS EXCLUSIONS AND CONDITIONS OF SUCH POLICIES LIMITS SHOWN MAY HAVE BEEN REDUCED BY PAID CLAIMS

CO LTR	TYPE OF INSURANCE	POLICY NUMBER	POLICY EFFECTIVE DATE (MM/DD/YY)	POLICY EXPIRATION DATE (MM/DD/YY)	LIMITS
A	GENERAL LIABILITY <input checked="" type="checkbox"/> COMMERCIAL GENERAL LIABILITY CLAIMS MADE <input checked="" type="checkbox"/> OCCJR OWNER'S & CONTRACTOR'S PROT	OMH3709388	08/19/00	08/19/01	GENERAL AGGREGATE \$2,000,000
					PRODUCTS COMP/OP AGG \$1,000,000
					PERSONAL & ADV NJURY \$1,000,000
					EACH OCCURRENCE \$1,000,000
					FIRE DAMAGE (Any one fire) \$ 50,000
					MED EXP (Any one person) \$ 5,000
A	AUTOMOBILE LIABILITY <input type="checkbox"/> ANY AUTO <input type="checkbox"/> ALL OWNED AUTOS <input type="checkbox"/> SCHEDULED AUTOS <input checked="" type="checkbox"/> HIRED AUTOS <input checked="" type="checkbox"/> NON-OWNED AUTOS	OMH3709388	08/19/00	08/19/01	COMBINED SINGLE LIMIT \$1,000,000
					BODILY INJURY (Per person) \$
					BODILY INJURY (Per accident) \$
					PROPERTY DAMAGE \$
	GARAGE LIABILITY <input type="checkbox"/> ANY AUTO				AUTO ONLY EA ACCIDENT \$
					OTHER THAN AUTO ONLY \$
					EACH ACCIDENT \$
					AGGREGATE \$
	EXCESS LIABILITY <input type="checkbox"/> UMBRELLA FORM <input type="checkbox"/> OTHER THAN UMBRELLA FORM				EACH OCCURRENCE \$
					AGGREGATE \$
	WORKERS COMPENSATION AND EMPLOYERS LIABILITY THE PROPRIETOR, PARTNERS/EXECUTIVE OFFICERS ARE <input type="checkbox"/> INCL <input type="checkbox"/> EXCL				WC STATU DAY LIMITS OTH EA
					EL EACH ACCIDENT \$
					EL DISEASE POLICY LIMIT \$
					EL DISEASE EA EMPLOYEE \$
A	OTHER HULL, IM, PROT & INDEMNITY POLLUTION	OMH3709389 OMH3490704	08/19/00 08/19/00	08/19/01 08/19/01	\$1,000,000 \$500,000/5,000,000

DESCRIPTION OF OPERATIONS/LOCATIONS/VEHICLES/SPECIAL ITEMS
PROTECTION & INDEMNITY INCLUDES TWO CAPTAINS

CERTIFICATE HOLDER
TOWN OF SEWALL'S POINT
1 S SEWALL'S POINT ROAD
SEWALL'S POINT, FL 34996

CANCELLATION
SHOULD ANY OF THE ABOVE DESCRIBED POLICIES BE CANCELLED BEFORE THE EXPIRATION DATE THEREOF, THE ISSUING COMPANY WILL ENDEAVOR TO MAIL 30 DAYS WRITTEN NOTICE TO THE CERTIFICATE HOLDER NAMED TO THE LEFT, BUT FAILURE TO MAIL SUCH NOTICE SHALL IMPOSE NO OBLIGATION OR LIABILITY OF ANY KIND UPON THE COMPANY, ITS AGENT'S OR REPRESENTATIVES
AUTHORIZED REPRESENTATIVE
Junda Bates

FILE
LICENS

nu

ACORD CERTIFICATE OF LIABILITY INSURANCE DATE (MM/DD/YY)
12/12/2000

PRODUCER
Workers' Compensation Specialists
PO Box 810909
Boca Raton, Florida, 33481-0909
(561) 989-0145

INSURED EXCEL ADMN SOLUTIONS, INC. EXCEL PERSONNEL, INC. EXCEL BENEFIT, IN 2120 N. DIXIE HIGHWAY BOCA RATON, FL 33431

THIS CERTIFICATE IS ISSUED AS A MATTER OF INFORMATION ONLY AND CONFERS NO RIGHTS UPON THE CERTIFICATE HOLDER. THIS CERTIFICATE DOES NOT AMEND, EXTEND OR ALTER THE COVERAGE AFFORDED BY THE POLICIES BELOW.

INSURERS AFFORDING COVERAGE

INSURER A GENERAL ACCIDENT INSURANCE CO
INSURER B
INSURER C
INSURER D
INSURER E

COVERAGES

THE POLICIES OF INSURANCE LISTED BELOW HAVE BEEN ISSUED TO THE INSURED NAMED ABOVE FOR THE POLICY PERIOD INDICATED. NOTWITHSTANDING ANY REQUIREMENT, TERM OR CONDITION OF ANY CONTRACT OR OTHER DOCUMENT WITH RESPECT TO WHICH THIS CERTIFICATE MAY BE ISSUED OR MAY PERTAIN, THE INSURANCE AFFORDED BY THE POLICIES DESCRIBED HEREIN IS SUBJECT TO ALL THE TERMS, EXCLUSIONS AND CONDITIONS OF SUCH POLICIES. AGGREGATE LIMITS SHOWN MAY HAVE BEEN REDUCED BY PAID CLAIMS.

ITEM	TYPE OF INSURANCE	POLICY NUMBER	POLICY EFFECTION DATE (MM/DD/YY)	POLICY EXPIRATION DATE (MM/DD/YY)	LIMITS
	GENERAL LIABILITY <input type="checkbox"/> COMMERCIAL GENERAL LIABILITY <input type="checkbox"/> CLAIMS MADE <input type="checkbox"/> OCCUR LEVEL AGGREGATE LIMIT APPLIES PER: <input type="checkbox"/> POLICY <input type="checkbox"/> PROJECT <input type="checkbox"/> LOC				EACH OCCURRENCE \$ PRE DAMAGE (Any one fire) \$ MED EXP (Any one person) \$ PERSONAL & ADV INJURY \$ GENERAL AGGREGATE \$ PRODUCTS COMP/OP AGG \$
	AUTOMOBILE LIABILITY <input type="checkbox"/> ANY AUTO <input type="checkbox"/> AL OWNED AUTOS <input type="checkbox"/> SCHEDULED AUTOS <input type="checkbox"/> HIRED AUTOS <input type="checkbox"/> NON-OWNED AUTOS				COMBINED SINGLE LIM* (EA accident) \$ BODILY INJURY (Per person) \$ BODILY INJURY (Per accident) \$ PROPERTY DAMAGE (Per accident) \$
	GARAGE LIABILITY <input type="checkbox"/> ANY AUTO				AUTO ONLY EA ACCIDENT \$ OTHER THAN EA ACC \$ AUTO ONLY AGG \$
	EXCESS LIABILITY <input type="checkbox"/> OCCUR <input type="checkbox"/> CLAIMS MADE DEDUCTIBLE \$ RETENTION \$				EACH OCCURRENCE \$ AGGREGATE \$ \$ \$
A	WORKERS COMPENSATION AND EMPLOYERS' LIABILITY	WC 0161741-01	04/01/00	04/01/01	WC BY ADJUTORY LIMITS X OTHER EL EACH ACCIDENT \$1,000,000 EL DISEASE EA EMPLOYEE \$1,000,000 EL DISEASE POLICY LIMIT \$1,000,000
	OTHER				

DESCRIPTION OF OPERATION/LOCATION/VEHICLES/EXCLUSIONS ADDED BY ENDORSEMENT/SPECIAL PROVISIONS

**EXCEL HUMAN RESOURCES, INC.
EMPLOYEES ON LEASE AND PROVIDED TO CUSTOM BUILT MARINE CONSTRUCTION, INC.

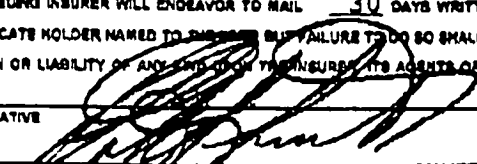
CERTIFICATE HOLDER	ADDITIONAL INSURED INSURER LETTER	CANCELLATION
TOWN OF SEWALL'S POINT 1 S SEWALL'S POINT ROAD SEWALL'S POINT, FL 34996		SHOULD ANY OF THE ABOVE DESCRIBED POLICIES BE CANCELLED BEFORE THE EXPIRATION DATE THEREOF, THE ISSUING INSURER WILL ENDEAVOR TO MAIL 30 DAYS WRITTEN NOTICE TO THE CERTIFICATE HOLDER NAMED TO THE INSURER. FAILURE TO DO SO SHALL IMPOSE NO OBLIGATION OR LIABILITY OF ANY KIND UPON THE INSURER, ITS AGENTS OR REPRESENTATIVES. AUTHORIZED REPRESENTATIVE 



MARTIN COUNTY, FLORIDA
Construction Industry Lic Bd
Certificate of Competency

License. SP01118
Expires September 30, 2001

CORRIGAN, DAVID H
CUSTOM BUILT MARINE CONST INC.
BOX 3016
STUART, FL 34995
MARINE CONTRACTOR

MARTIN COUNTY ORIGINAL
2001 COUNTY OCCUPATIONAL LICENSE 2001

Larry C O'Steen, Tax Collector, P O. Box 9013, Stuart, FL 34995
(561) 288-5604

LICENSE 1988 520 255 CERT SP01118

PHONE 561 288 4254 SIC NO 1629

LOCATION

950 COLORADO AVE

00000

CHARACTER COUNTS IN MARTIN COUNTY

PREV YR \$ 0.00 LIC FEE \$ 25.00
\$ 0.00 PENALTY \$ 0.00
\$ 0.00 COL FEE \$ 0.00
\$ 0.00 TRANSFER \$ 0.00
TOTAL 25.00

IS HEREBY LICENSED TO ENGAGE IN THE BUSINESS, PROFESSION OR OCCUPATION
OF MARINE CONSTR CONTRACTOR

AT ABOVE ADDRESS FOR THE PERIOD BEGINNING ON THE

1 DAY OF OCTOBER 2000
AND ENDING SEPTEMBER 30 2001 12 80802 78 PAID

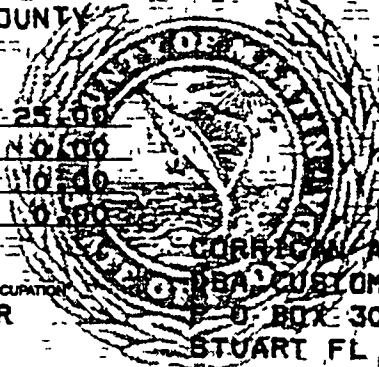

CORRIGAN AND COMPANY
CORPORATION
PO BOX 3016
STUART FL 34995

MARTIN COUNTY ORIGINAL
2000 COUNTY OCCUPATIONAL LICENSE 2001

Larry C O'Steen, Tax Collector, P.O. Box 9013, Stuart, FL 34995
(561) 288-5604

LICENSE 1988 267 431 CERT

PHONE 305 288 4254 SIC NO 0782

LOCATION

950 COLORADO AVE

00000

CHARACTER COUNTS IN MARTIN COUNTY

PREV YR \$ 0.00 LIC FEE \$ 25.00
\$ 0.00 PENALTY \$ 0.00
\$ 0.00 COL FEE \$ 0.00
\$ 0.00 TRANSFER \$ 0.00
TOTAL 25.00

IS HEREBY LICENSED TO ENGAGE IN THE BUSINESS, PROFESSION OR OCCUPATION
OF LANDSCAPING

AT ABOVE ADDRESS FOR THE PERIOD BEGINNING ON THE

1 DAY OF OCTOBER 2000
AND ENDING SEPTEMBER 30 2001 12 80802 77 PAID

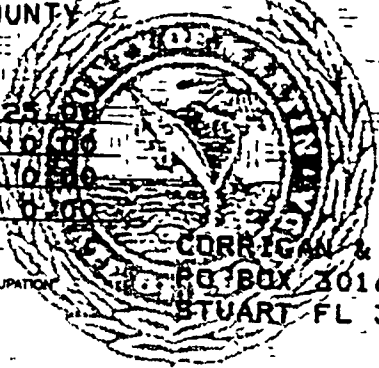

CORRIGAN & CO
PO BOX 3016
STUART FL 34995

MARTIN COUNTY ORIGINAL
2000 COUNTY OCCUPATIONAL LICENSE 2001

Larry C O'Steen, Tax Collector, P O Box 9013, Stuart, FL 34995
(561) 288-5604

LICENSE 1900 283 013 CERT

PHONE 561 288 4254 SIC NO 8000

LOCATION

950 COLORADO AVE 30

CHARACTER COUNTS IN MARTIN COUNTY

PREV YR \$ 0.00 LIC FEE \$ 25.00
\$ 0.00 PENALTY \$ 0.00
\$ 0.00 COL FEE \$ 0.00
\$ 0.00 TRANSFER \$ 0.00
TOTAL 25.00

IS HEREBY LICENSED TO ENGAGE IN THE BUSINESS, PROFESSION OR OCCUPATION
OF MOVABLE BUSINESS

AT ABOVE ADDRESS FOR THE PERIOD BEGINNING ON THE

9 DAY OF AUGUST 2000
AND ENDING SEPTEMBER 30 2001

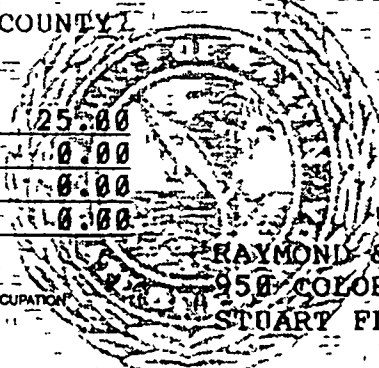

RAYMOND & DAVID CORRIGAN
950 COLORADO AVE E 30
STUART FL 34994

RECEIPT OF PAYMENT 1
L.C. O'STEEN, T.C. NORMAL
99-08/09/2000.OCC NORMAL
1900283013
022000809004046CK \$25.00

NOTICE OF COMMENCEMENT

Must be completed when construction value exceeds \$2500

Permit # _____
State of Florida _____

Tax Folio # _____
County of MARTIN

The undersigned hereby gives notice that improvement will be made to certain real property, and in accordance with Chapter 713, Florida Statutes, the following information is provided in this Notice of Commencement

LEGAL DESCRIPTION OF PROPERTY, include Street address, if available

Section 35 Twp 37S Range 41E
103 N Sewalls Pt Rd Sewalls Pt

General Description of Improvements Remove boat house & platform

Reduce width of access + construct 22x5 terminal platform

Owner Henry M Rothberg Address 103 N Sewalls Pt Rd Sewalls Pt

Owner's interest in property _____

Fee Simple Title Holder, if other than owner _____

Address _____

Contractor Custom Built Marine Const 3170 SE WAALER ST Stuart

Surety Company, if any _____

Address _____ Amt of Bond _____

Lender's Name _____ Address _____

Persons within the State of Florida designated by Owner upon whom notices of other documents may be served as provided by Section 713 13(1)(a) 7, Florida Statutes

Name _____ Address _____

In addition to himself, Owner designates _____ of _____

to receive a copy of the Lienor's Notice as provided in Section 713 13(1)(b), Florida Statutes

Expiration date of notice of commencement is one year from the date of recording

Michael Rando
Signature of Owner

Sworn and subscribed before me this 6 day of Nov 2000

Margy Barz
Notary Public
My commission expires 5-25-04



STATE OF FLORIDA
MARTIN COUNTY

THIS IS TO CERTIFY THAT THE
FOREGOING _____ PAGES IS A TRUE
AND CORRECT COPY OF THE ORIGINAL

MARSHA STILLER, CLERK
BY [Signature] DC
DATE 11-8-00

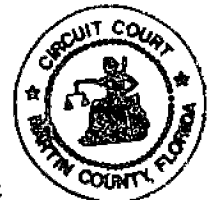



Department of Environmental Protection

Jeb Bush
Governor

Port St. Lucie Branch Office
1801 SE Hillmoor Drive
Suite C-204
Port St. Lucie, FL 34952
(561)398-2806

David B. Struhs
Secretary

OCT 02 2000

Henry M. Rothberg
3218 NW 62nd Street
Boca Raton, FL 33416

File Number 43-0165717-002
Martin County

Dear Mr. Rothberg

22'

On September 26, 2000, we received your application for an exemption to perform the following activities: remove a 1,200 square foot boathouse and a 12.5' by 8' triangular platform, reduce the width of the access from 6' wide to 5' wide, construct a 24' by 5' terminal platform with an associated mooring area for a total of 995 square feet of structure in the St. Lucie River, Class III waters of the state located at 103 N. Sewalls Point Road (Section 35, Township 37 South, Range 41 East) Stuart, Martin County.

Your application has been reviewed to determine whether it qualifies for any of three kinds of authorization that may be necessary for works in wetlands or waters of the United States. The kinds of authorization are (1) regulatory authorization, (2) proprietary authorization (related to state-owned submerged lands), and (3) federal authorization. The authority for review and the outcomes of the reviews are listed below. Please read each section carefully. Your project may not have qualified for all three forms of authorization. If your project did not qualify for one or more of the authorizations, refer to the specific section dealing with that authorization for advice on how to obtain it.

1 Regulatory Review - EXEMPTION VERIFIED

The Department has the authority to review your project under Part IV of Chapter 373, Florida Statutes (F.S.), Title 62, Florida Administrative Code (F.A.C.) and in accordance with operating agreements executed between the Department and the water management districts, as referenced in Chapter 62-113, F.A.C.

Based on the information you submitted, we have determined that your project is exempt from the need to obtain a DEP Environmental Resource Permit under Rule 40E-4.051(3)(b), (F.A.C.)

2 Proprietary Review (related to state-owned lands) - GRANTED

The Department acts as staff to the Board of Trustees of the Internal Improvement Trust Fund (B.O.T.) and issues certain authorizations for the use of sovereign submerged lands. The Department has the authority to review your project under Chapters 253 and 258, F.S., Chapters 18-20 and 18-21, F.A.C., and Section 62-343.075, F.A.C.

Your project may occur on sovereign submerged land and may require authorization from the Board of Trustees to use public property. As staff to the Board of Trustees, we have reviewed the proposed project and have determined that, as long as it is located within the described boundaries and is consistent with the attached general consent conditions, the project qualifies for consent to use sovereign submerged lands. Therefore, pursuant to Chapter 253.77, Florida Statutes, you may consider this letter as authorization from the Board of Trustees for the upland riparian owner to perform the project.

12/11/00 TOWN OF SEWALLS POINT
REVIEW: [Signature]
REG. OFFICIAL

More Protection, Less Process

Printed on recycled paper

PIO _____

FILE TOWN COPY
103 N. SEWALLS PT. RD

Henry M. Rothberg
File Number 43-0165717-002
Page Two

3 Federal Review (State Programmatic General Permit) - AUTHORIZATION GRANTED

Federal authorization for the proposed project is reviewed by DEP pursuant to an agreement between the Department and the U.S. Army Corps of Engineers (the Corps). The agreement is outlined in a document titled *Coordination Agreement Between the U.S. Army Corps of Engineers and the Florida Department of Environmental Protection State Programmatic General Permit Section 10 of the Rivers and Harbor Act of 1899 and Section 404 of the Clean Water Act*.

Your project has been reviewed for compliance with a State Programmatic General Permit (SPGP). Your proposed activity as outlined on the attached drawings is in compliance with the SPGP program. U.S. Army Corps of Engineers (Corps) General conditions apply to your project, as attached. **No further permitting for this activity is required by the Corps.** The authority granted under this SPGP expires December 17, 2003. Your project must be completed prior to this expiration date.

The determinations in this letter are based solely on the information provided to the Department and on the statutes and rules in effect when the application was submitted. The determinations are effective only for the specific activity proposed. These determinations shall automatically expire if site conditions materially change or if the governing statutes or rules are amended. In addition, any substantial modifications in your plans should be submitted to the Department for review, as changes may result in a permit being required. In any event, this determination shall expire after one year.

This letter does not relieve you from the responsibility of obtaining other permits (federal, state, or local) that may be required for the project.

NOTICE OF RIGHTS OF SUBSTANTIALLY AFFECTED PERSONS

This letter acknowledges that the proposed activity is exempt from ERP permitting requirements under Rule 40E-4.051(3)(b), F.A.C. This determination is final and effective on the date filed with the Clerk of the Department unless a sufficient petition for an administrative hearing is timely filed under sections 120.569 and 120.57 of the Florida Statutes as provided below. If a sufficient petition for an administrative hearing is timely filed, this determination automatically becomes only proposed agency action subject to the result of the administrative review process. Therefore, on the filing of a timely and sufficient petition, this action will not be final and effective until further order of the Department. The procedures for petitioning for a hearing are set forth in the attached notice.

This determination is based on the information you provided the Department and the statutes and rules in effect when the application was submitted and is effective only for the specific activity proposed. This determination shall automatically expire if site conditions materially change or the governing statutes or rules are amended. In addition, any substantial modifications in your plans should be submitted to the Department for review, as changes may result in a permit being required. In any event, this determination shall expire after one year.

Be advised that your neighbors and other parties who may be substantially affected by the proposed activity allowed under this determination of exemption have a right to request an administrative hearing on the Department's decision that the proposed activity qualifies for this exemption. Because the administrative hearing process is designed to redetermine final agency action on the application, the filing of a petition for an administrative hearing may result in a final determination that the proposed activity is not authorized under the exemption established under Rule 40E-4.051(3)(b), F.A.C.

Henry M Rothberg
File Number 43-0165717-002
Page Three

The Department will not publish notice of this determination. Publication of this notice by you is optional and is not required for you to proceed. However, in the event that an administrative hearing is held and the Department's determination is reversed, proceeding with the proposed activity before the time period for requesting an administrative hearing has expired would mean that the activity was conducted without the required permit.

If you wish to limit the time within which all substantially affected persons may request an administrative hearing, you may elect to publish, at your own expense, the enclosed notice (Attachment A) in the legal advertisement section of a newspaper of general circulation in the county where the activity is to take place. A single publication will suffice.

If you wish to limit the time within which any specific person(s) may request an administrative hearing, you may provide such person(s), by certified mail, a copy of this determination, including Attachment A.

For the purposes of publication, a newspaper of general circulation means a newspaper meeting the requirements of sections 50.011 and 50.031 of the Florida Statutes. In the event you do publish this notice, within seven days of publication, you must provide to the following address proof of publication issued by the newspaper as provided in section 50.051 of the Florida Statutes. If you provide direct written notice to any person as noted above, you must provide to the following address a copy of the direct written notice.

Florida Department of Environmental Protection, Southeast District - Port St. Lucie Branch Office
Submerged Lands & Environmental Resources Program, 1801 SE Hillmoor Drive, Suite C-204
Port St. Lucie, FL 34952

Thank you for applying to the Submerged Lands and Environmental Resource Program. If you have questions regarding this matter, please contact **Danna Civetti** of this office, at telephone number (561)398-2806.

Sincerely,

Danna Civetti

for Gary N. Roderick
Environmental Administrator

GNR/DC *js*

Enclosures General Consent Conditions
Federal General/Specific Conditions for SPGP III- R1 and Transfer Request
Federal Manatee Conditions
Attachment A- Notice of Determination of Qualification for Exemption
Attachment D- General Single-Family Dock Information

cc U.S. Army Corps of Engineers, Stuart [without enclosures]
Custom Built Marine Construction, Inc. (Agent) [without enclosures]

SEE MAP NO 94&95

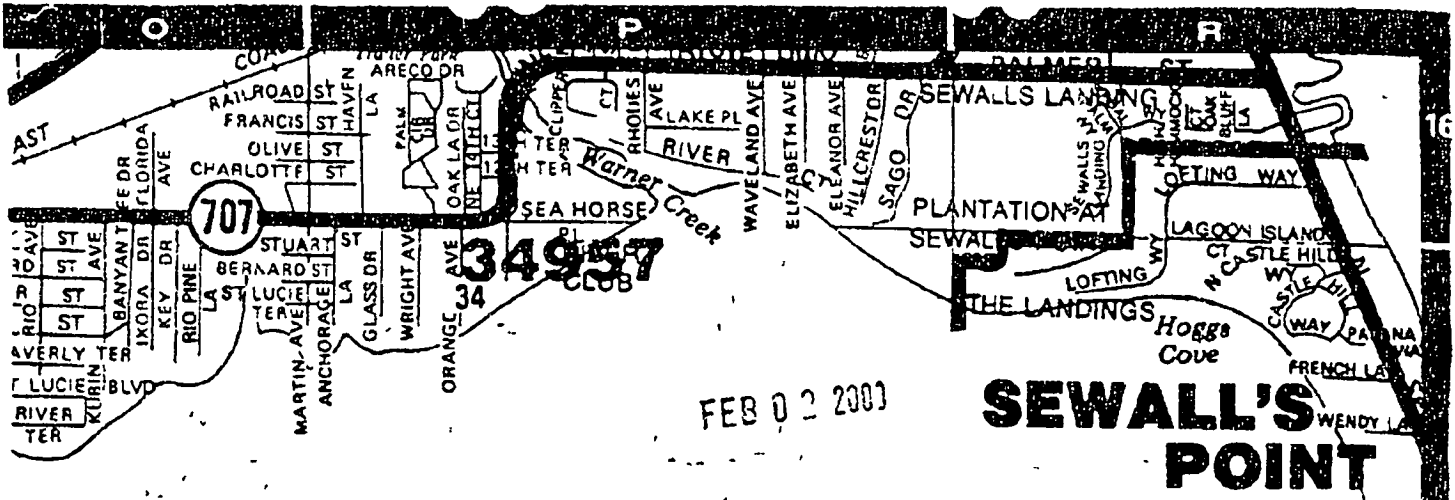

SEWALL'S POINT

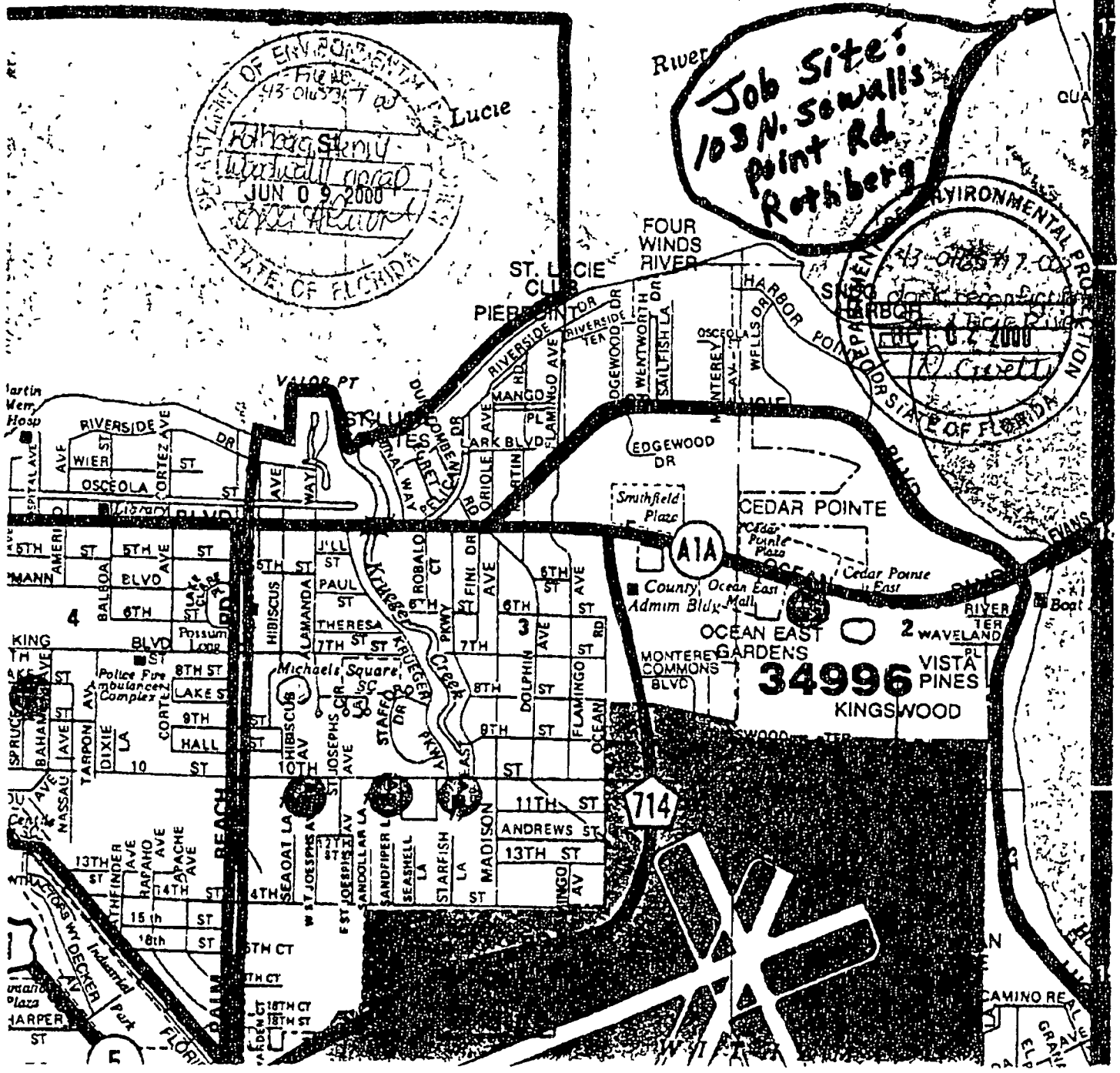

SFP 7 6 2000

Dept of Environ. Protection
Port St. Lucie
Hazardous Gas & Piles
Elastite Ties & Drains

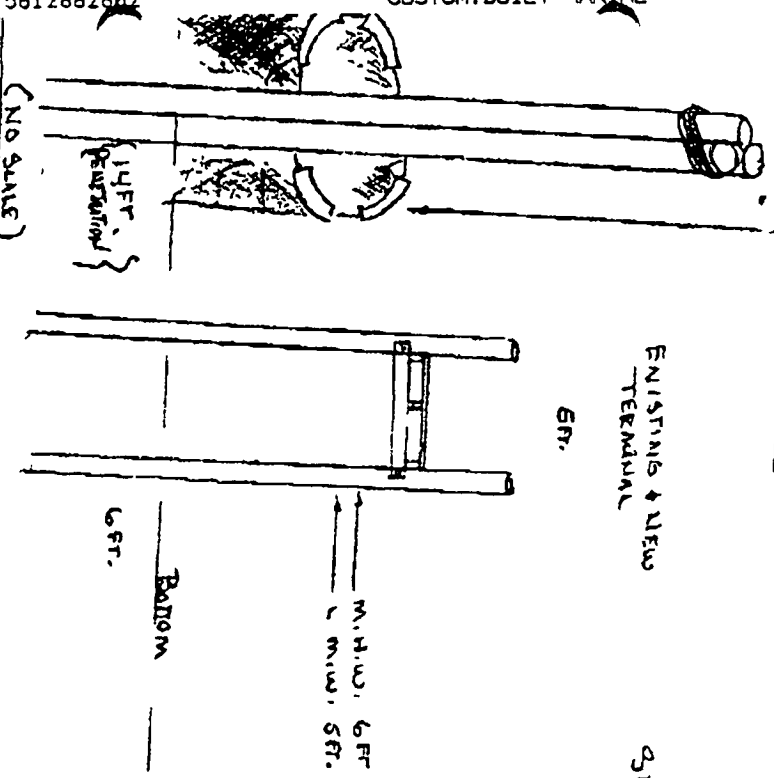

ST. LUCIE RIVER
CLASS III WATERS

RIPARIAN

STAIN BUILT MARINE CONSTRUCTION, INC.
10 S.W. WALTER STREET
DADE CITY, FL 34902
TLC 561-298-4254
FAX 561-298-2802
WEB SITE WWW.CRMARINE.COM

103 N SEWALLS POINT ROAD
SEWALLS, FL. 34996
SECT. 35 TWP. 37 SOUTH RANGE 41 EAST MATRIN COUNTY
RECONFIGURE EXISTING DOCK AND DRAIN SIZE TO 995 S.F. TO
MATCH EXISTING CRUISE AND REC. PIER PLANS

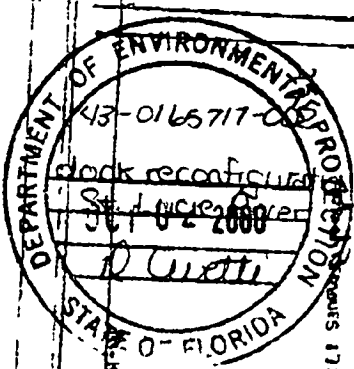

NOTE: TOTAL RECONFIGURED DOCK WITH NEW SURVIVAL TERMINAL PLATFORMS (995 S.F.)

NOTE: DOCK ACCESS EXISTING 6 FT. WIDE REDUCE 5 FT. WIDE PLATFORMS 175 S.F.

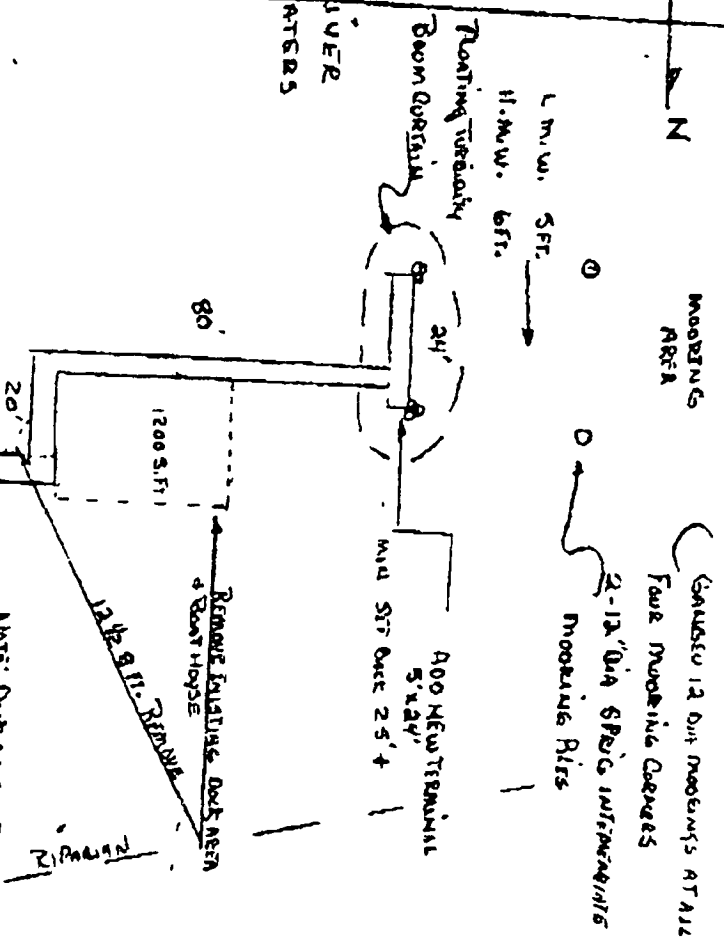

INSTALL 12 OUT MOORINGS AT ALL FOUR MOORING CORNERS
2-12" DIA 6" SIG. W/TERMINALS MOORING PILES

L.M.W. 5 FT.
H.M.W. 6 FT.

FLUATING TIE-INS
BOOM CURTAIN
MINI-SECT
DIA 25'+

CUSTOM BUILT MARINE CONSTRUCTION INC.

3170 SE Waaler Street
Phone (561)288-4254

Stuart, Florida 34997
Fax (561)288-2802



November 3, 2000

RE Rothberg Residence
103 N Sewalls Point Road
Sewall's Point, FL

To Whom It May Concern

I have no objection to the Rothbergs rebuilding their dock and constructing a new upland retaining wall with rock placed in front on waterside, as long as the Rothbergs comply with all local and state codes, and the existing dock with 5' by 22' terminal end does not impede my navigation and also does not exceed the 25' riparian setback

Keith E Ingram
Neighbor Signature

11/8/00
Date

Keith Ingram 101 N Sewalls Pt. Rd Sewalls Pt. FL 34996
Print Neighbor's Name

Katherine D Stone
Notary Public



CUSTOM BUILT MARINE CONSTRUCTION INC.

3170 SE Waler Street
Phone (561)288-4254

Stuart, Florida 34997
Fax (561)288-2802



November 3, 2000

RE Rothberg Residence
103 N Sewalls Point Road
Sewall's Point, FL

To Whom It May Concern.

I have no objection to the Rothbergs rebuilding their dock ~~and constructing a new upland retaining wall with rock placed in front on waterside~~, as long as the Rothbergs comply with all local and state codes, and the existing dock with 5' by 22' terminal end does not impede my navigation and also does not exceed the 25' riparian setback

[Signature]
Neighbor Signature

6 Nov 00
Date

BERNARD LAWSON, 11 Wendy Ln. Sewalls Pt. FL 34996
Print Neighbor's Name

Katherine D Stone
Notary Public

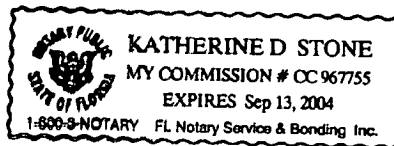

NEW TERMINAL PLATFORM 5'x24'

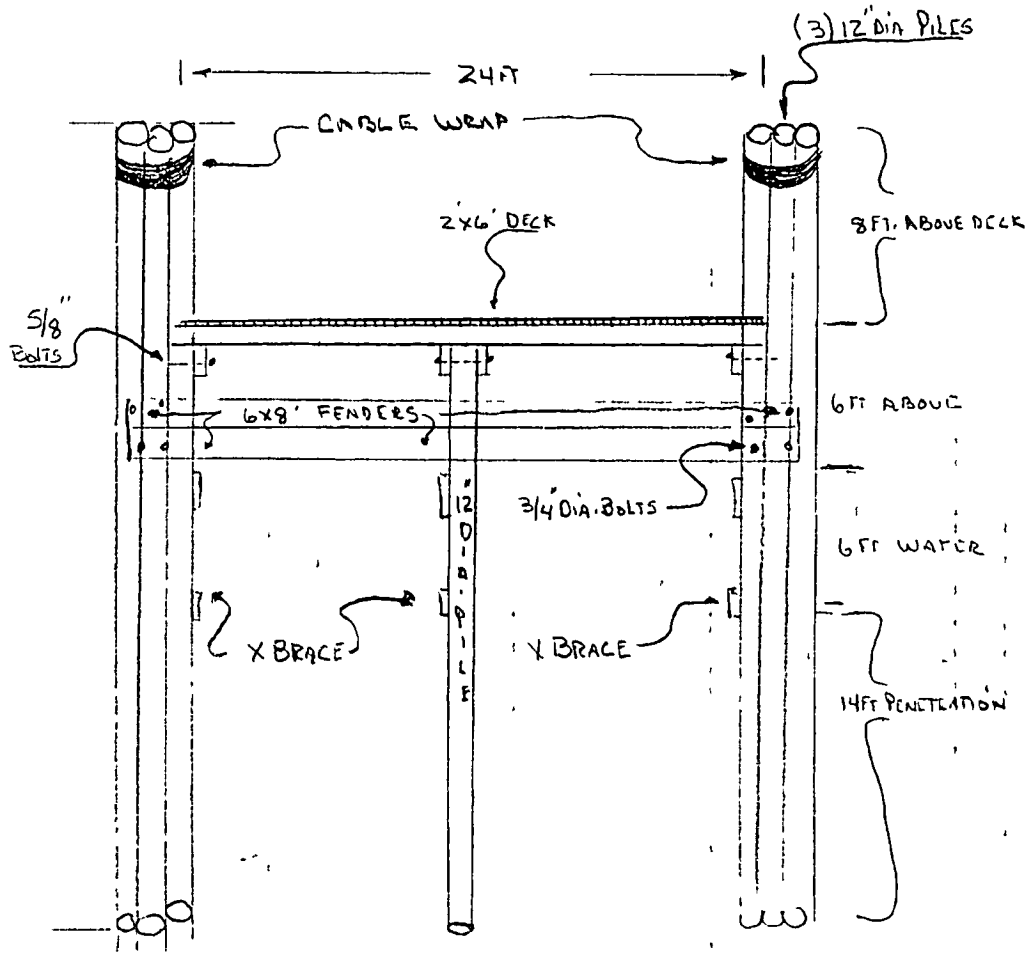

SCALE 1/8" = 1 FT.

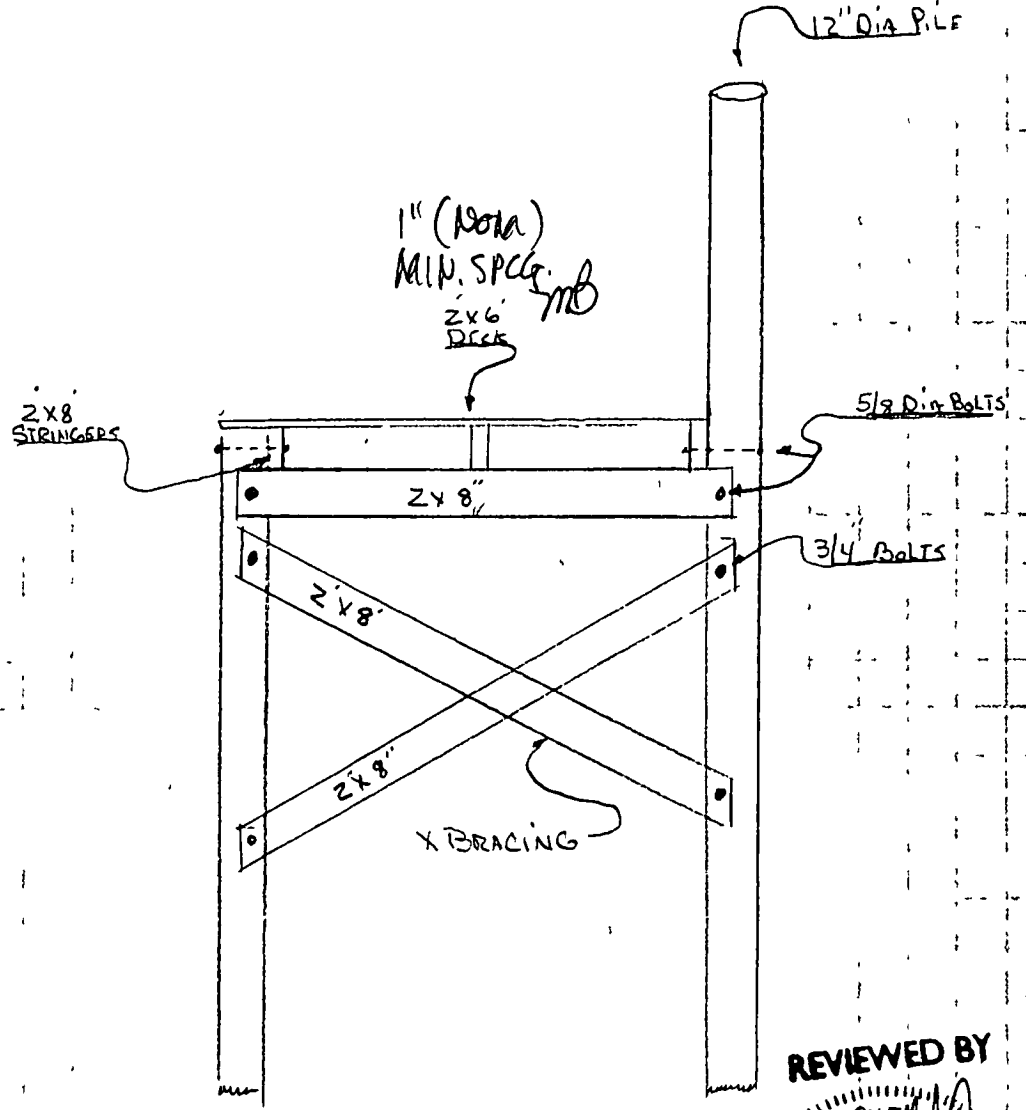

#20 SCALE

REVIEWED BY

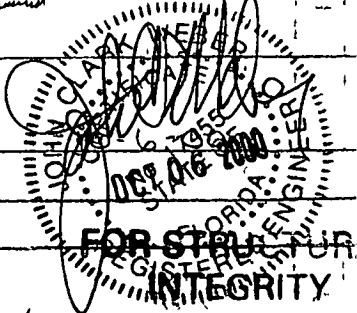

CUSTOM BUILT MARINE CONSTRUCTION, INC.

3170 S.E. WALKER STREET

STUART, FL. 34997

PHONE 561-288-4254

FAX 561-288-2802

WEBSITE WWW.PRINCIPAL.COM

ROTHBERG RESIDENCE

103 N. SEWALLS POINT ROAD

SEWALLS POINT, FL. 34996

PROPOSED TERMINAL DOCK 5' WIDE X 24' LONG
WITH MOORING AND FENDER SYSTEM

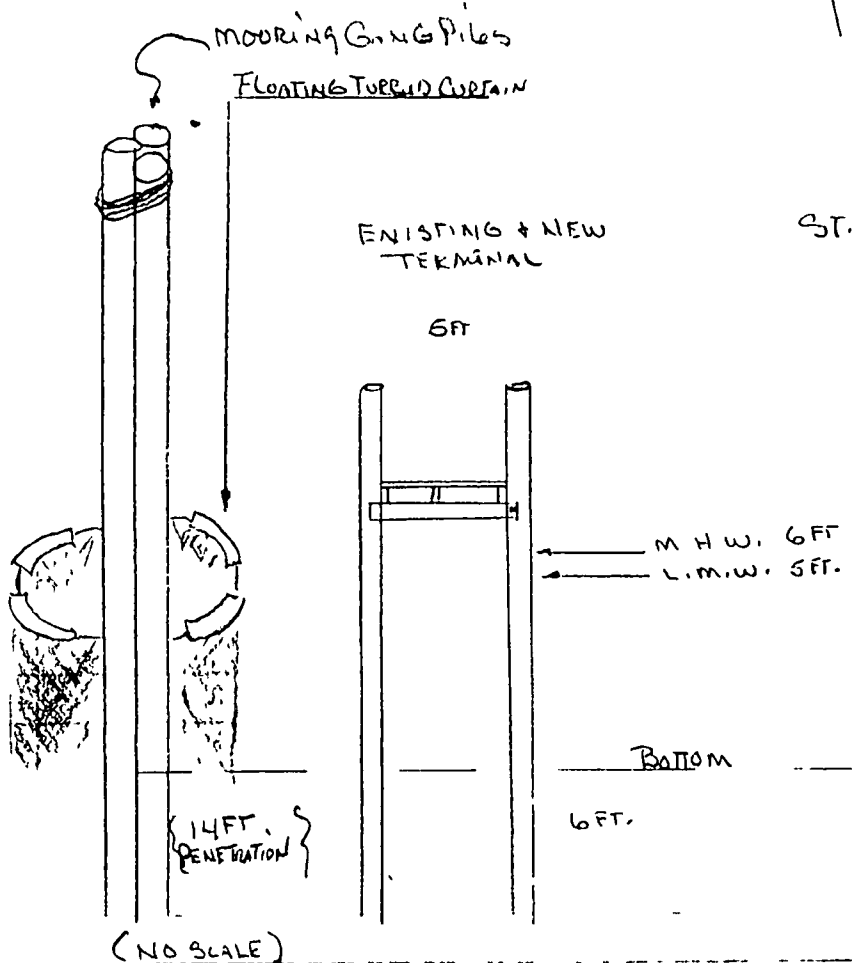

ST. LUCIE RIVER
CLASS III WATERS

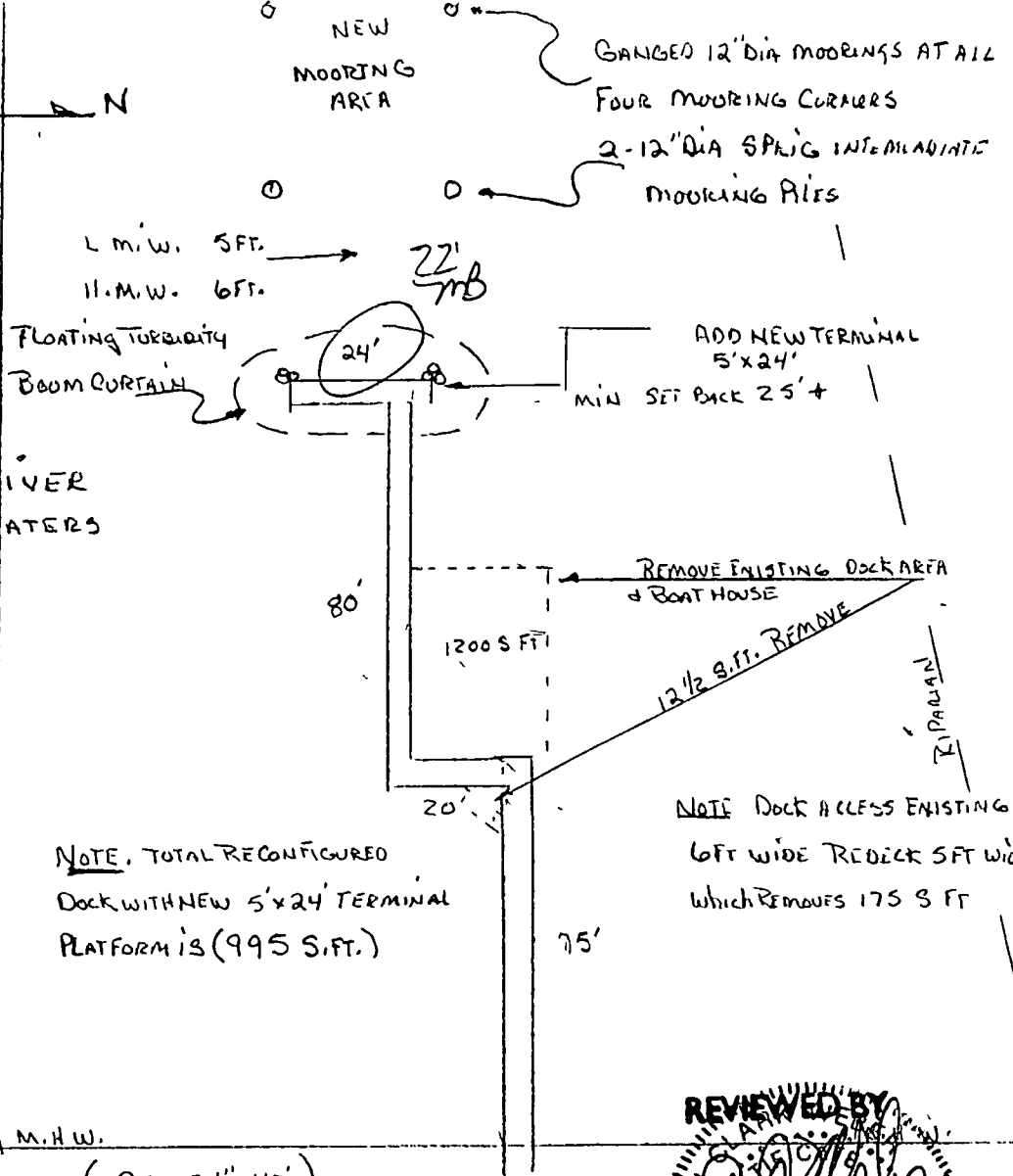

NOTE. TOTAL RECONFIGURED DOCK WITH NEW 5'x24' TERMINAL PLATFORM IS (995 S.F.T.)

NOTE DOCK ACCESS EXISTING 6 FT WIDE REDECK 5 FT WIDE WHICH REMOVES 175 S FT

CUSTOM BUILT MARINE CONSTRUCTION, INC.
3700 S.E. WAHLER STREET
STUART, FL. 34997
PHONE 561-288-4254
FAX 561-288-2802
WEBSITE WWW.CBMARINE.COM

HENRY ROTH BERG RESIDENCE
103 N. SEWALLS POINT ROAD
SEWALLS, FL. 34996
SEC. 35 TWP. 37 SOUTH RANGE 4 EAST
RECONFIGURE EXISTING DOCK AND DOWN SIZE TO 995 S FT. TO MINIMIZE CRITERIA AND PRE EMPT RISKS

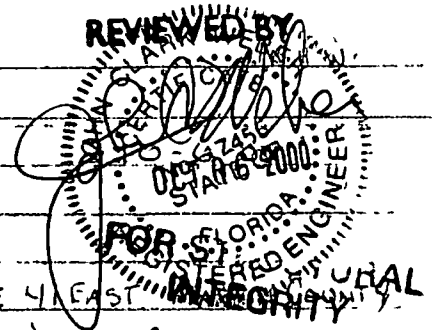

5280

RETAINING WALL

&

RIPRAP

MASTER PERMIT NO. N/A

TOWN OF SEWALL'S POINT

Date 2/28/01 BUILDING PERMIT NO. 5280
 Building to be erected for HENRY M. ROTHBERG Type of Permit RET. WALL/RIP RAP
 Applied for by CUSTOM BUILT MARINE CONST. (Contractor) Building Fee \$480.00
 Subdivision GOV LOT 2 Lot _____ Block _____ Radon Fee _____
 Address 103 N. SEWALL'S POINT RD. Impact Fee _____
 Type of structure S.F.R. A/C Fee _____
 Electrical Fee _____
 Plumbing Fee _____
 Roofing Fee _____
 Amount Paid \$528.00 Check # 15114 Cash _____ Other Fees (REV) 48.00
 Total Construction Cost \$ 50,000.00 TOTAL Fees \$528.00

Signed [Signature] Applicant
 Signed [Signature] Town Building Inspector OFFICIAL

RETAINING WALL PERMIT

INSPECTIONS			
SETBACKS	DATE _____	BACKFILL	DATE _____
TIE-BACKS	DATE _____	FINAL	DATE <u>8/6/01</u>

24 HOURS NOTICE REQUIRED FOR INSPECTIONS. CALL 287-2455

WORK HOURS – 8:00 AM UNTIL 5:00 PM

MONDAY THROUGH SATURDAY

New Construction Remodel Addition Demolition

This permit must be visible from the street, accessible to the inspector.
FURTHER CONDITIONS ARE SET FORTH IN THE APPLICATION FOR PERMIT,
NOTATIONS ON THE APPROVED SUBMITTALS, AND ATTACHMENTS IN THE PERMIT FILE.
DO NOT FASTEN THIS OR ANY OTHER SIGN TO A TREE!



**Town of Sewall's Point
BUILDING PERMIT APPLICATION**

Bldg Permit Number 5280

RECEIVED

Owner or Titleholder's Name Henry M Rothberg Phone No. (601) 498 4617

Street: 103 N Sewalls Point Rd City Sewalls Point State FL Zip 34996

Legal Description of Property. Section 35, Twp 37S Range 41E Martin Co

Parcel Number: 35 37 41 000 000 0017

Location of Job Site: Same

TYPE OF WORK TO BE DONE: Construct 21ft wood retain wall, backfill & riprap

CONTRACTOR/Company Name Custom Built Marine Const Phone No (501) 288 4200

Street: 3170 SE WAALER ST City Stuart State FL Zip 34997

State Registration _____ State License: SP01118

ARCHITECT: CUSTOM BUILT MARINE CONSTRUCTION, INC Phone No () 288-4254

Street: 3170 S.E WAALER ST City STUART State FL Zip 34997

ENGINEER: MR. JACK WEBBER Phone No () 229-2722

Street: _____ City _____ State FL Zip _____

AREA SQUARE FOOTAGE - SEWER - ELECTRICITY _____

Living Area: _____ Garage Area: 1309 Accessory Bldg: _____

Covered Patio _____ Scr Porch _____ Wood Deck WOOD WALL + ROCK REVETMENT

Type Sewage: _____ Septic Tank Permit # from Health Dept. _____

New Electrical Service Size _____ AMPS

FLOOD HAZARD INFORMATION

Flood zone: _____ Minimum Base Flood Elevation (BFE) _____ NGVD

Proposed first habitable floor finished elevation _____ NGVD (minimum 1 foot above BFE)

COSTS AND VALUES \$ 50,000.00

Estimated cost of construction or improvement \$ _____

Estimated Fair Market Value (FMV) prior to improvement \$ _____

If Improvement, is cost greater than 50% of Fair Market Value? YES _____ NO

Method of determining Fair Market Value _____

SUBCONTRACTOR INFORMATION. (Notification to this office of subcontractor change is mandatory.)

Electrical _____ State _____ License # _____

Mechanical _____ State _____ License # _____

Plumbing: _____ State _____ License # _____

Roofing: _____ State _____ License # _____

Application is hereby made to obtain a permit to do the work and installations as indicated I certify that no work or installation has commenced prior to the issuance of a permit and that all work will be performed to meet the standard of all laws regulating construction in this jurisdiction I understand that a separate permit from the Town may be required for ELECTRICAL, PLUMBING, SIGNS, WELLS, POOLS, FURNACES, BOILERS, HEATERS, TANKS, AIR CONDITIONERS, DOCKS, SEA WALLS, ACCESSORY BUILDINGS, SAND OR FILL ADDITION OR REMOVAL, AND TREE REMOVAL.

I HEREBY CERTIFY THAT THE INFORMATION I HAVE FURNISHED ON THIS APPLICATION IS TRUE AND CORRECT TO THE BEST OF MY KNOWLEDGE AND I AGREE TO COMPLY WITH ALL APPLICABLE CODES, LAWS AND ORDINANCES DURING THE BUILDING PROCESS, INCLUDING FLORIDA MODEL ENERGY CODES.

OWNER or AGENT SIGNATURE (Required)

Mehmet Kalkan

State of Florida, County of Martin On

this the 4 day of Oct, 2000,

by _____ who is personally

known to me or produced _____

as identification.

Margy Barz
Notary Public

My Commission Expires: 5-15-04

CONTRACTOR SIGNATURE (Required)

DAVID CORRIGAN

State of Florida, County of Martin On

this the 4 day of Oct, 2000,

by _____ who is personally

known to me or produced _____

as identification.

Margy Barz
Notary Public

My Commission Expires: 5-15-04

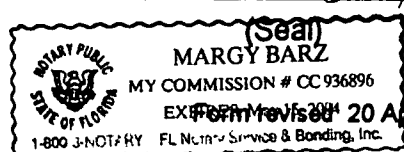

TREE REMOVAL (Attach sealed survey)

Number of trees to be removed: 0 Number of trees to be retained _____ Number of trees to be planted: 0 Number of Specimen trees removed: _____
Fee: \$ _____ Authorized/Date: _____

DEVELOPMENT ORDER # _____

1. ALL APPLICATIONS REQUIRE

- a. Property Appraisers Parcel Number.
- b. Legal Description of your property. (Can be found on your deed survey or Tax Bill.)
- c. Contractors name, address, phone number & license numbers.
- d. Name all sub-contractors (properly licensed)
- e. Current Survey

2. Take completed application to the Permits and Inspections Office for approval. Provide construction details and a plot plan(s) showing setbacks, yard coverage, parking and position of all buildings on the property, stormwater retention plan, etc. Compliance with subdivision regulations can also be determined at this time

3. Take the application showing Zoning approval (complete with plans & plot plan) to the Health Department for septic tank. Attach the pink copy to the building application.

4. Return all forms to the Permits and Inspection Office. All planned construction requires: two (2) sets of plans, drawn to scale with engineer's or architects seal and the following items.

- a. Floor Plan
- b. Foundation Details
- c. Elevation Views - Elevation Certificate due after slab inspection,
- d. Plot Plan (show desired floor elevation relative to Sea Level in front of building, plus location of driveway).
- e. Truss layout
- f. Vertical Wall Sections (one detail for each wall that is different)
- g. Fireplace drawing: If prefabricated submit manufacturers data

ADDITIONAL Required Documents are.

- 1. Use permit (for driveway connection to public Right of Way). Return form with plot plan showing driveway location (State Road A-1-A East Ocean Boulevard only).
- 2. Well Permit or information on existing well & pump.
- 3. Flood Hazard Elevation (if applicable).
- 4. Energy Code Compliance Certification plus any Approved Forms and/or Energy Code Compliance Sheets
- 5. Statement of Fact (for Homeowner Builder), and proof of ownership (Deed or Tax receipt).
- 6. Irrigation Sprinkler System layout showing location of heads, valves, etc
- 7. A certified copy of the Notice of Commencement must be filed in this office and posted at the job site prior to the first inspection
- 8. Replat required upon completion of slab or footing inspection And Prior to any further inspections.

NOTICE: In addition to the requirements of this permit, there may be additional restrictions applicable to this property that may be found in the public records of COUNTY OF MARTIN, and there may be additional permits required from other governmental entities such as water management districts, state and federal agencies

Approved by Building Official _____ Date _____

Approved by Town Engineer _____ Date _____
(If required)

ACORD CERTIFICATE OF LIABILITY INSURANCE DATE (MM/DD/YY) **12/12/00**

PRODUCER
 WORKERS' COMP SPECIALISTS, INC
 P.O. BOX 810909
 BOCA RATON, FL 33481-0909

THIS CERTIFICATE IS ISSUED AS A MATTER OF INFORMATION ONLY AND CONFERS NO RIGHTS UPON THE CERTIFICATE HOLDER. THIS CERTIFICATE DOES NOT AMEND, EXTEND OR ALTER THE COVERAGE AFFORDED BY THE POLICIES BELOW.

INSURED
 CUSTOM-BUILT MARINE CONSTRUCTION, INC.
 3170 SE WAALER STREET
 STUART, FL 34997

COMPANIES AFFORDING COVERAGE
 COMPANY A GREAT AMERICAN INSURANCE COMPANY
 COMPANY B
 COMPANY C
 COMPANY D

FILE
left in
FILE
Permit

COPY RECEIVED
 BY: *[Signature]*

COVERAGE
 THIS IS TO CERTIFY THAT THE POLICIES OF INSURANCE LISTED BELOW HAVE BEEN ISSUED TO THE INSURED NAMED ABOVE FOR THE POLICY PERIOD INDICATED, NOTWITHSTANDING ANY REQUIREMENT, TERM OR CONDITION OF ANY CONTRACT OR OTHER DOCUMENT WITH RESPECT TO WHICH THIS CERTIFICATE MAY BE ISSUED OR MAY PERTAIN, THE INSURANCE AFFORDED BY THE POLICIES DESCRIBED HEREIN IS SUBJECT TO ALL THE TERMS EXCLUSIONS AND CONDITIONS OF SUCH POLICIES LIMITS SHOWN MAY HAVE BEEN REDUCED BY PAID CLAIMS

CO LTR	TYPE OF INSURANCE	POLICY NUMBER	POLICY EFFECTIVE DATE (MM/DD/YY)	POLICY EXPIRATION DATE (MM/DD/YY)	LIMITS
A	GENERAL LIABILITY <input checked="" type="checkbox"/> COMMERCIAL GENERAL LIABILITY <input type="checkbox"/> CLAIMS MADE <input checked="" type="checkbox"/> OCCUR <input type="checkbox"/> OWNER'S & CONTRACTOR'S PROT	OMH3709388	08/19/00	08/19/01	GENERAL AGGREGATE \$2,000,000 PRODUCTS COMP/OP AGG \$1,000,000 PERSONAL & ADV INJURY \$1,000,000 EACH OCCURRENCE \$1,000,000 FIRE DAMAGE (Any one fire) \$ 50,000 MED EXP (Any one person) \$ 5,000
A	AUTOMOBILE LIABILITY <input type="checkbox"/> ANY AUTO <input type="checkbox"/> ALL OWNED AUTOS <input type="checkbox"/> SCHEDULED AUTOS <input checked="" type="checkbox"/> HIRED AUTOS <input checked="" type="checkbox"/> NON-OWNED AUTOS	OMH3709388	08/19/00	08/19/01	COMBINED SINGLE LIMIT \$1,000,000 BODILY INJURY (Per person) \$ BODILY INJURY (Per accident) \$ PROPERTY DAMAGE \$
	GARAGE LIABILITY <input type="checkbox"/> ANY AUTO				AUTO ONLY EA ACCIDENT \$ OTHER THAN AUTO ONLY \$ EACH ACCIDENT \$ AGGREGATE \$
	EXCESS LIABILITY <input type="checkbox"/> UMBRELLA FORM <input type="checkbox"/> OTHER THAN UMBRELLA FORM				EACH OCCURRENCE \$ AGGREGATE \$
	WORKERS COMPENSATION AND EMPLOYERS' LIABILITY THE PROPRIETOR PARTNER/EXECUTIVE OFFICERS ARE <input type="checkbox"/> INCL <input type="checkbox"/> EXCL				WC STATU "C"RY LIMITS OTH EA EL EACH ACCIDENT \$ EL DISEASE POLICY LIMIT \$ EL DISEASE EA EMPLOYEE \$
A	OTHER HULL, IM, PROT & INDEMNITY POLLUTION	OMH3709389 OMH3490704	08/19/00 08/19/00	08/19/01 08/19/01	\$1,000,000 \$500,000/\$5,000,000

DESCRIPTION OF OPERATIONS/LOCATION/VEHICLE/SPECIAL ITEMS
 PROTECTION & INDEMNITY INCLUDES TWO CAPTAINS

CERTIFICATE HOLDER
 TOWN OF SEWALL'S POINT
 1 S SEWALL'S POINT ROAD
 SEWALL'S POINT, FL 34996

CANCELLATION
 SHOULD ANY OF THE ABOVE DESCRIBED POLICIES BE CANCELLED BEFORE THE EXPIRATION DATE THEREOF, THE ISSUING COMPANY WILL ENDEAVOR TO MAIL 30 DAYS WRITTEN NOTICE TO THE CERTIFICATE HOLDER NAMED TO THE LEFT, BUT FAILURE TO MAIL SUCH NOTICE SHALL IMPOSE NO OBLIGATION OR LIABILITY OF ANY KIND UPON THE COMPANY, ITS AGENT'S OR REPRESENTATIVES

AUTHORIZED REPRESENTATIVE
Junda Bates

FILE
LICENS

ACORD CERTIFICATE OF LIABILITY INSURANCE

DATE (MM/DD/YY)
12/12/2000

PRODUCER
Workers' Compensation Specialists
PO Box 810909
Boca Raton, Florida, 33481-0909
(561) 989-0145

INSURED
EXCEL ADMN SOLUTIONS, INC. EXCEL
PERSONNEL, INC. EXCEL BENEFIT, IN
2120 N. DIXIE HIGHWAY
BOCA RATON, FL 33431

THIS CERTIFICATE IS ISSUED AS A MATTER OF INFORMATION ONLY AND CONFERS NO RIGHTS UPON THE CERTIFICATE HOLDER. THIS CERTIFICATE DOES NOT AMEND, EXTEND OR ALTER THE COVERAGE AFFORDED BY THE POLICIES BELOW.

INSURERS AFFORDING COVERAGE

INSURER A: GENERAL ACCIDENT INSURANCE CO
INSURER B:
INSURER C:
INSURER D:
INSURER E:

COVERAGES

THE POLICIES OF INSURANCE LISTED BELOW HAVE BEEN ISSUED TO THE INSURED NAMED ABOVE FOR THE POLICY PERIOD INDICATED. NOTWITHSTANDING ANY REQUIREMENT, TERM OR CONDITION OF ANY CONTRACT OR OTHER DOCUMENT WITH RESPECT TO WHICH THIS CERTIFICATE MAY BE ISSUED OR MAY PERTAIN, THE INSURANCE AFFORDED BY THE POLICIES DESCRIBED HEREIN IS SUBJECT TO ALL THE TERMS, EXCLUSIONS AND CONDITIONS OF SUCH POLICIES. AGGREGATE LIMITS SHOWN MAY HAVE BEEN REDUCED BY PAID CLAIMS.

TYPE OF INSURANCE	POLICY NUMBER	POLICY EFFECTIVE DATE (MM/DD/YY)	POLICY EXPIRATION DATE (MM/DD/YY)	LIMITS
GENERAL LIABILITY <input type="checkbox"/> COMMERCIAL GENERAL LIABILITY <input type="checkbox"/> CLAIMS MADE <input type="checkbox"/> OCCUR SEVL AGGREGATE LIMIT APPL'ES PER <input type="checkbox"/> POLICY <input type="checkbox"/> PROJ <input type="checkbox"/> LOC				EACH OCCURRENCE \$ FIRE DAMAGE (Any one fire) \$ MED EXP (Any one person) \$ PERSONAL & ADV INJURY \$ GENERAL AGGREGATE \$ PRODUCTS COMP/OP AGC \$
AUTOMOBILE LIABILITY <input type="checkbox"/> ANY AUTO <input type="checkbox"/> ALL OWNED AUTOS <input type="checkbox"/> SCHEDULED AUTOS <input type="checkbox"/> HIRED AUTOS <input type="checkbox"/> NON-OWNED AUTOS				COMBINED SINGLE LMT (Ea accident) \$ BODILY INJURY (Per persn) \$ BODILY INJURY (Per accident) \$ PROPERTY DAMAGE (Per accident) \$
GARAGE LIABILITY <input type="checkbox"/> ANY AUTO				AUTO ONLY - EA ACCIDENT \$ OTHER THAN AUTO ONLY EA ACC \$ AGG \$
EXCESS LIABILITY <input type="checkbox"/> OCCUR <input type="checkbox"/> CLAIMS MADE <input type="checkbox"/> DEDUCTIBLE \$ <input type="checkbox"/> RETENTION \$				EACH OCCURRENCE \$ AGGREGATE \$ \$
WORKERS COMPENSATION AND EMPLOYERS' LIABILITY A	WC 0161741-01	04/01/00	04/01/01	<input type="checkbox"/> WC BY AUTO <input checked="" type="checkbox"/> STATUTORY LIMITS <input checked="" type="checkbox"/> PER \$1,000,000 \$1,000,000 \$1,000,000
OTHER				

DESCRIPTION OF OPERATIONS/LOCATION/VEHICLE/EXCLUSIONS ADDED BY ENDORSEMENT/SPECIAL PROVISIONS

**EXCEL HUMAN RESOURCES, INC.
EMPLOYEES ON LEASE AND PROVIDED TO CUSTOM BUILT MARINE CONSTRUCTION, INC.

CERTIFICATE HOLDER	ADDITIONAL INSURED INSURER LETTER	CANCELLATION
TOWN OF SEWALL'S POINT 1 S SEWALL'S POINT ROAD SEWALL'S POINT, FL 34996		SHOULD ANY OF THE ABOVE DESCRIBED POLICIES BE CANCELLED BEFORE THE EXPIRATION DATE THEREOF, THE ISSUING INSURER WILL ENDEAVOR TO MAIL 30 DAYS WRITTEN NOTICE TO THE CERTIFICATE HOLDER NAMED TO THE INSURER. FAILURE TO DO SO SHALL IMPOSE NO OBLIGATION OR LIABILITY OF ANY KIND UPON THE INSURER, ITS AGENTS OR REPRESENTATIVES. AUTHORIZED REPRESENTATIVE

ACORD 28-S (7/87)

© ACORD CORPORATION 1988

1 2 2000 04

WORKERS COMPENSATION SPECIALISTS

Dec 12 2000 10 10 AM



MARTIN COUNTY, FLORIDA
Construction Industry Lic Bd
Certificate of Competency

License: SP01118
Expires September 30, 2001

CORRIGAN, DAVID H
CUSTOM BUILT MARINE CONST INC.
BOX 3016
STUART, FL 34995
MARINE CONTRACTOR

COUNTY OCCUPATIONAL LICENSE 2001

PHONE 561 288 4254 SIC NO 1629

Larry C. O'Steen, Tax Collector, P.O. Box 9013, Stuart, FL 34995 (561) 288-5604

LOCATION

950 COLORADO AVE

00000

CHARACTER COUNTS IN MARTIN COUNTY

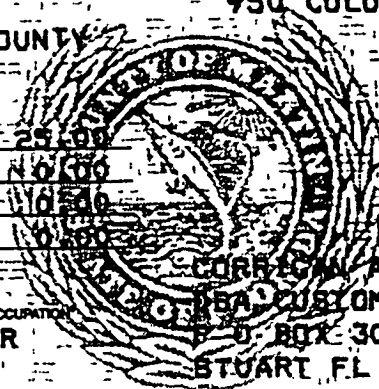

PREV YR. \$ 0.00 LIC FEE \$ 25.00
PENALTY \$ 0.00 COL FEE \$ 0.00
TRANSFER \$ 0.00
TOTAL 25.00

CORRIGAN AND COMPANY
P.O. BOX 3016
STUART FL 34995

IS HEREBY LICENSED TO ENGAGE IN THE BUSINESS, PROFESSION OR OCCUPATION OF MARINE CONSTR CONTRACTOR

AT ABOVE ADDRESS FOR THE PERIOD BEGINNING ON THE

1 DAY OF OCTOBER 2000
AND ENDING SEPTEMBER 30 2001 12 80802 78 PAID

MARTIN COUNTY ORIGINAL

2000 COUNTY OCCUPATIONAL LICENSE 2001

LICENSE 1988 267 431 CERT

PHONE 305 288 4254 SIC NO 0782

LOCATION

950 COLORADO AVE

00000

CHARACTER COUNTS IN MARTIN COUNTY

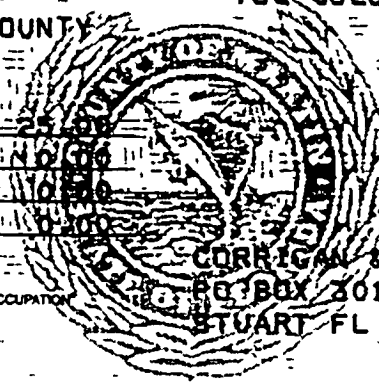

PREV YR. \$ 0.00 LIC FEE \$ 25.00
PENALTY \$ 0.00 COL FEE \$ 0.00
TRANSFER \$ 0.00
TOTAL 25.00

CORRIGAN & CO
P.O. BOX 3016
STUART FL 34995

IS HEREBY LICENSED TO ENGAGE IN THE BUSINESS, PROFESSION OR OCCUPATION OF LANDSCAPING

AT ABOVE ADDRESS FOR THE PERIOD BEGINNING ON THE

1 DAY OF OCTOBER 2000
AND ENDING SEPTEMBER 30 2001 12 80802 77 PAID

MARTIN COUNTY ORIGINAL

2000 COUNTY OCCUPATIONAL LICENSE 2001

LICENSE 1900 283 013 CERT

PHONE 561 288 4254 SIC NO 0000

LOCATION

950 COLORADO AVE 30

00000

CHARACTER COUNTS IN MARTIN COUNTY

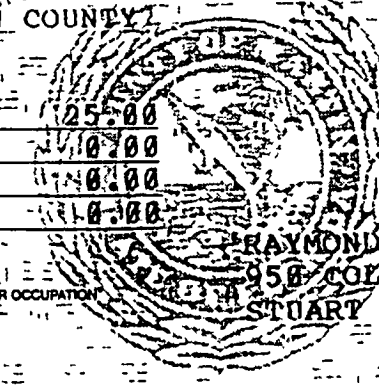

PREV YR \$ 0.00 LIC FEE \$ 25.00
PENALTY \$ 0.00 COL FEE \$ 0.00
TRANSFER \$ 0.00
TOTAL 25.00

RAYMOND & DAVID CORRIGAN
950 COLORADO AVE E 30
STUART FL 34994

IS HEREBY LICENSED TO ENGAGE IN THE BUSINESS, PROFESSION OR OCCUPATION OF MOVABLE BUSINESS

AT ABOVE ADDRESS FOR THE PERIOD BEGINNING ON THE

9 DAY OF AUGUST 2000
AND ENDING SEPTEMBER 30 2001

RECEIPT OF PAYMENT
L.C. O'STEEN, T.C. 9000
99-08/09/2000 OCC NORMAL
1900283013 \$25.00
022000809004046CK

NOTICE OF COMMENCEMENT

Must be completed when construction value exceeds \$2500

Permit # _____
State of Florida

Tax Folio # _____
County of MARTIN

The undersigned hereby gives notice that improvement will be made to certain real property, and in accordance with Chapter 713, Florida Statutes, the following information is provided in this Notice of Commencement

LEGAL DESCRIPTION OF PROPERTY, include Street address, if available

Section 35 Twp 37S Range 41E
103 N Sewalls Pt Rd Sewalls Pt

General Description of Improvements Install 2181ft wood
Return well

Owner Henry M Roxbury Address 103 N Sewalls Pt Rd Sewalls Pt

Owner's interest in property _____

Fee Simple Title Holder, if other than owner _____

Address _____

Contractor Custom Built & Marine Const Address 3170 SE WAALER ST STUART

Surety Company, if any _____

Address _____ Amt of Bond _____

Lender's Name _____ Address _____

Persons within the State of Florida designated by Owner upon whom notices of other documents may be served as provided by Section 713 13(1)(a) 7, Florida Statutes

Name _____ Address _____

In addition to himself, Owner designates _____ of _____

to receive a copy of the Lienor's Notice as provided in Section 713 13(1)(b), Florida Statutes

Expiration date of notice of commencement is one year from the date of recording

Mechawell
Signature of Owner

Sworn and subscribed before me this 6 day of Nov 2000

Margy Barz
Notary Public
My commission expires 5-15-04



DEPUTY CLERK T Copus (temp supervis
MARTIN COUNTY Florida
MARSHA EWING
RECORDED 11/08/2000 03:16 PM
OR BK 01515 PG 1086
INSTR # 1464910

ROBERT M WIENKE
Mayor

TOWN OF SEWALL'S POINT

JOSEPH C DORSKY
Town Manager

MARC S TEPLITZ
Vice Mayor

JOAN H BARROW
Town Clerk

DAWSON C GLOVER, III
Commissioner

LARRY E McCARTY
Chief of Police

THOMAS P BAUSCH
Commissioner

EDWIN B ARNOLD
Building Official

E DANIEL MORRIS
Commissioner

JOSE TORRES, JR
Maintenance



February 23, 2001

FILE

David H Corrigan, Qualifier
Custom Built Marine Const , Inc
3170 SE Waaler Street
Stuart, FL 34997

COPY

Re Permit Application - Upland Retaining Wall/Rip Rap
103 N Sewall's Point Road
Henry M Rothberg

Dear Mr Corrigan

On February 20, 2001, the Town Commission approved a variance to allow buffer zone construction as required in conjunction with the scope of work under the referenced application. Building Department review has been completed, and I am prepared to issue the permit for this work upon payment of the requisite permit fee in the amount of \$528.00.

Feel free to contact me if you have any questions or require further assistance.

Sincerely,

Edwin B Arnold, AIA, CBO
Building Official

cc Thomas P Bausch, Building Commissioner
Joseph C Dorsky, Town Manager



One South Sewall's Point Road, Sewall's Point, Florida 34996
Town Hall (561) 287-2455 • Fax (561) 220-4765 • E-Mail clerk@sewallspoint.org
Police Department (561) 781-3378 • Fax (561) 286-7669 • E-Mail police@sewallspoint.org

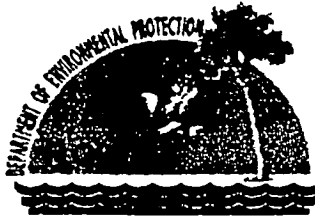

Job Bush
Governor

Department of Environmental Protection

Southeast District
P O Box 15425
West Palm Beach, Florida 33416

David B. Struhs
Secretary

CONSOLIDATED ENVIRONMENTAL RESOURCE PERMIT AND SOVEREIGN SUBMERGED LANDS AUTHORIZATION

PERMITTEE/AUTHORIZED ENTITY:

Henry Rothberg
103 N Sewall's Point Rd
Stuart, FL 34996

Permit/Authorization No 43-0165717-001

Date of Issue **JUN 09 2000**

Expiration Date of

Construction Phase **JUN 08 2005**

County Martin

Project Retaining wall and riprap

This permit is issued under the authority of Part IV of Chapter 373, Florida Statutes (F S), and Title 62, Florida Administrative Code (F A C) The activity is not exempt from the requirement to obtain an Environmental Resource Permit Pursuant to Operating Agreements executed between the Department and the water management districts, as referenced in Chapter 62-113, F A C , the Department is responsible for reviewing and taking final agency action on this activity

ACTIVITY DESCRIPTION:

The purpose of the project is to install a 218 linear foot wood retaining wall, to backfill approximately 80 cubic yards and to install riprap at the toe of the retaining wall The riprap will extend out greater than 8 feet but less than 10 feet from the toe of the proposed retaining wall

ACTIVITY LOCATION:

The project is located at 103 N Sewall's Point Rd , in the St Lucie River, Class III waters of the state, (Section 35, Township 37 South, Range 41 East), Stuart, Martin County

This permit also constitutes a finding of consistency with Florida's Coastal Zone Management Program, as required by Section 307 of the Coastal Management Act

This permit also constitutes certification of compliance with water quality standards under Section 401 of the Clean Water Act, 33 U S C 1341

This activity also requires a proprietary authorization, as the activity is located on sovereign submerged lands owned by the Board of Trustees of the Internal Improvement Trust Fund, pursuant to Article X, Section 11 of the Florida Constitution, and Sections 253 002 and 253 77, F S The activity is not exempt from the need to obtain a proprietary authorization The Department has the responsibility to review and take final action on this request for proprietary authorization in accordance with Section 18-21 0051, and the Operating Agreements executed between the Department and the water management districts, as referenced in Chapter 62-113, F A C In addition to the above, this proprietary authorization has been reviewed in accordance with Chapter 253, F S , Chapter 18-21, Section 62-343 075, F A C , and the policies of the Board of Trustees

"Protect, Conserve and Manage Florida's Environment and Natural Resources"



Job Bush
Governor

Department of Environmental Protection

Marjory Stoneman Douglas Building
3900 Commonwealth Boulevard
Tallahassee Florida 32399-3000
Bureau of Surveying and Mapping
Mail Station 105

David B. Struhs
Secretary

Notice of Mean High Water Survey Filing

Date 11-17-00 County MORTON Waterbody ST. LUCIE RIVER
 Project Vicinity SEWELL'S PT. SEC 35 TWP 37 RNG 41
 Job No./Name 00-1015-04-01 Client Name CUSTOM BUILT MARINE COAST.
 USGS 7.5-Minute Quad Map Name ST. LUCIE INLET
 Surveyor Name DAVID W SCHRYVER PSM# 4864
 Business Name GLY, INC.
 Mailing Address P.O. BOX 1669
 City, State, Zip DALMA CITY, FL. 34991
 Phone (561) 226-8083 FAX 223-6174 Email DAVID@GLYINC.COM

Data below this line to be completed by the Bureau of Surveying and Mapping

An executed copy of this form will be returned to the Surveyor

The above Mean High Water Survey has been filed in the Bureau of Surveying and Mapping public repository.

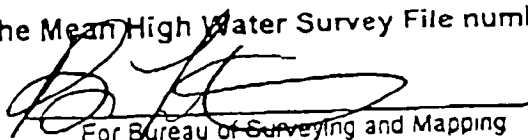
The Mean High Water Survey File number is 2476

 For Bureau of Surveying and Mapping Date 11, 21, 00

*When completed assemble the Mean High Water Survey Package, consisting of the following:

1. Mean High Water Survey Procedural Approval
2. Notice of Mean High Water Survey Filing (this sheet)
3. Mean High Water Survey Checklist

Staple to a single, paper copy of the signed/sealed survey drawing(s), folded to 8"x12"
Send to the letterhead address

MHW11rev731filing

*Protect, Conserve and Manage Florida's Environment and Natural Resources



Job Bush
Governor

Department of Environmental Protection

Margory Sconeman Douglas Building
3900 Commonwealth Boulevard
Tallahassee Florida 32399-3000
Bureau of Surveying and Mapping
Mail Station 105

David B. Struhs
Secretary

FILE

Notice of Mean High Water Survey Filing

Date 11-17-00 County MOBILE Waterbody ST. LUCIE RIVER
 Project Vicinity SEWELL'S PT. SEC 35 TWP 37 RNG 41
 Job No./Name 00-1015-04-01 Client Name CUSTOM BUILT MARINE COAST.
 USGS 7.5-Minute Quad Map Name ST. LUCIE INLET
 Surveyor Name DAVID W. SCHRYVER PSM # 4864
 Business Name GLY, INC.
 Mailing Address P.O. BOX 1669
 City, State, Zip DOLAN CITY, FL. 34991
 Phone (561) 206-8083 FAX 283-6174 Email DAVID@GLYINC.COM

Data below this line to be completed by the Bureau of Surveying and Mapping

An executed copy of this form will be returned to the Surveyor

The above Mean High Water Survey has been filed in the Bureau of Surveying and Mapping public repository.

The Mean High Water Survey File number is

2476

For Bureau of Surveying and Mapping

11/21/00
Date

- *When completed, assemble the Mean High Water Survey Package, consisting of the following
- 1 Mean High Water Survey Procedural Approval
 2. Notice of Mean High Water Survey Filing (this sheet)
 - 3 Mean High Water Survey Checklist

Staple to a single, paper copy of the signed/sealed survey drawing(s), folded to 8"x12"
Send to the letterhead address

MHW11rev7316ing

"Protect, Conserve and Manage Florida's Environment and Natural Resources"

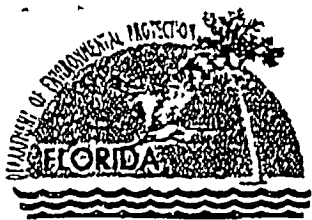

Jeb Bush
Governor

Department of Environmental Protection

FILE

Marjory Stoneman Douglas Building
3900 Commonwealth Boulevard
Tallahassee Florida 32399-3000

David B. Struhs
Secretary

Your Job No	00-1015-04-01
MHW File No	_____

MEAN HIGH WATER SURVEY CHECKLIST

The Mean High Water (MHW) Survey will be entered into the public repository if it meets or exceeds the following Department standards. Please review the MHW Survey drawing(s) to assure each of the listed items is properly addressed. **A single paper copy of the survey drawing(s) must be signed/sealed and dated.**

- 1 The MHW survey drawing size is (a) 8 1/2" x 14", (b) 11" x 17" or (c) 24" x 36"
- 2 MHW survey submitted within 90 days after completion of work (see Chapter 177.37 F.S.)
- 3 A note stating Elevations indicated hereon are in feet and decimals referenced to NGVD 1929 or other, as applicable
- 4 One on-site tidal bench mark for each project is shown (three tidal bench marks required per each subordinate tide station if performing simultaneous tidal observations) and described with datum reference indicated, for example (a) 5.21 feet, NGVD 1929, (b) 1.256 meters, NAVD 1988 or (c) other, as applicable
- 5 The horizontal location of the MHW line complete with bearings and distances and a notation of the method used to locate the line are to be included
- 6 A note stating Mean High Water elevation x.xx feet, NGVD 1929 as located on ___/___/___ [date] (to be placed near the mean high water line)
- 7 A location map is included on the drawing (USGS 1:24,000 scale preferred)
- 8 A note stating type of survey (a) Mean High Water Survey (b) Boundary and Mean High Water Survey, or (c) other, as applicable
- 9 A completed copy of the Mean High Water Survey Procedural Approval is attached to and submitted with the MHW Survey drawing(s).
- 10 A note stating The Mean High Water Survey depicted hereon complies with Chapter 177, Part II, Florida Statutes and is recorded in the public repository of the Florida Department of Environmental Protection, Bureau of Surveying and Mapping as Mean High Water Survey File _____

BSM will use this checklist to review the Mean High Water Survey drawing(s)

Upon review and acceptance by the Bureau of Surveying and Mapping (BSM) a Notice of Mean High Water Survey Filing, noting the Mean High Water Survey file number, will be sent / faxed to you

A single paper copy (signed / sealed) of the MHW survey drawing(s) shall be sent to:

Department of Environmental Protection
Bureau of Surveying and Mapping
Mail Station 105
3900 Commonwealth Blvd.
Tallahassee, Florida 32399

MHW (4-00-02) (03/01)

"Protect, Conserve and Manage Florida's Environment and Natural Resources"

Printed on recycled paper

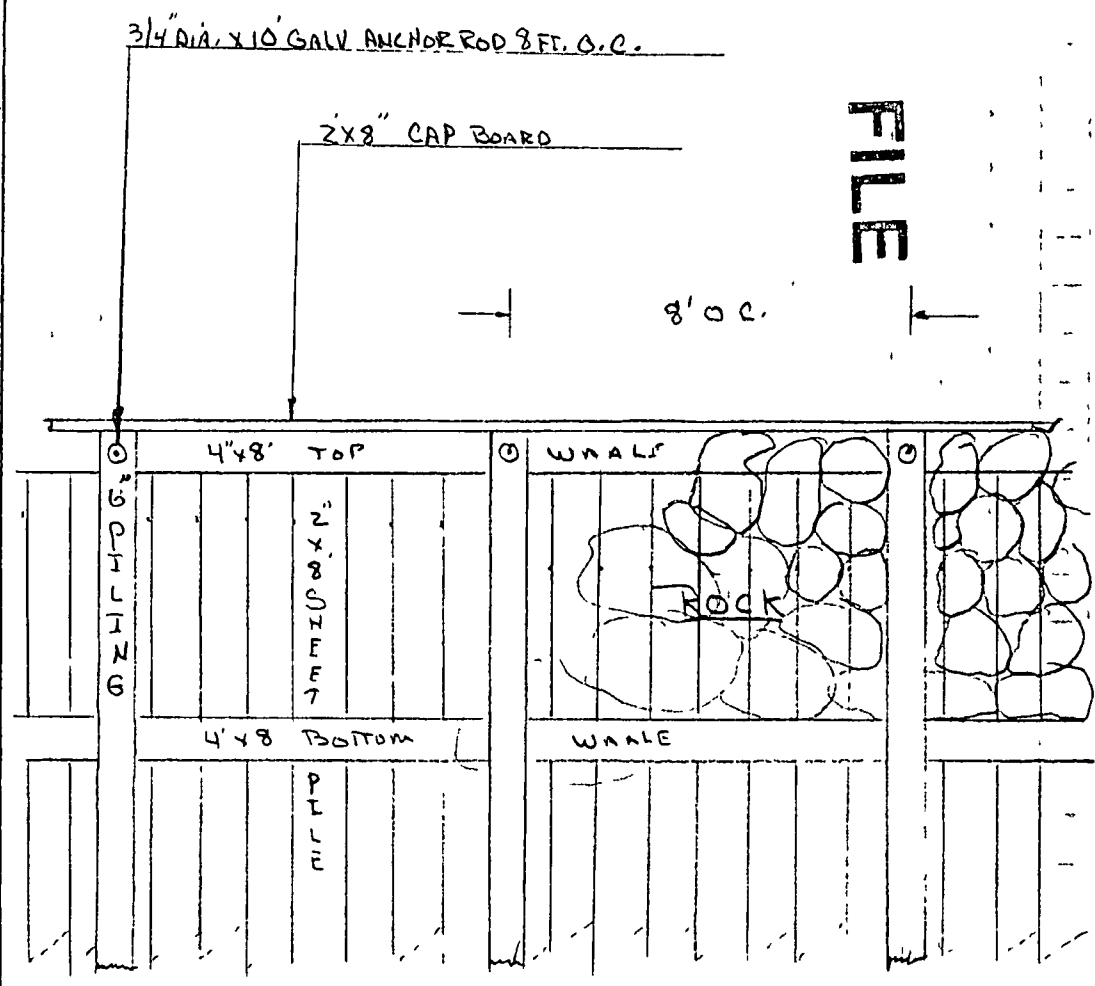
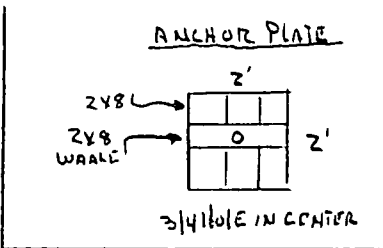
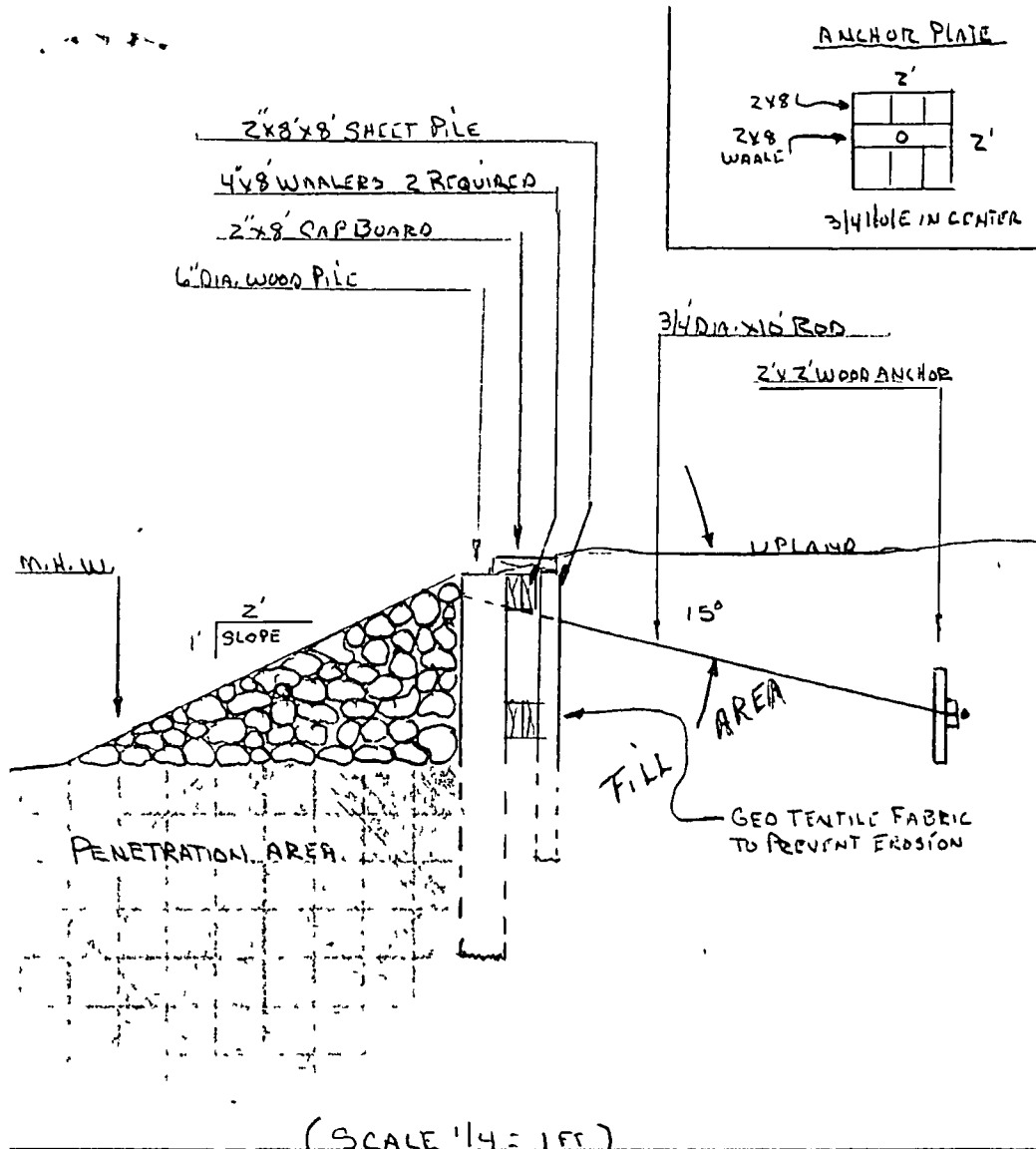

FILE

CUSTOM BUILT MARINE CONSTRUCTION, INC.
 3170 S.E. WALKER ST.
 STUART, FL.
 PHONE 561-288-4254
 FAX 561-288-2802
 WEB SITE WWW.CBMBINE.COM

ROTH BERG RESIDENCE
 103 NORTH SEWALLS POINT ROAD
 SEWALLS PT., FL.
 RETAINING WALL AND ROCK REVETMENT

REVIEWED BY:
 JOHN CLAYTON
 REGISTERED PROFESSIONAL ENGINEER
 STATE OF FLORIDA
 REG. NO. 18620001
 APR 10 2008
 FOR STRUCTURAL INTEGRITY

LEGAL DESCRIPTION

THAT PART OF THE NORTH HALF OF GOVERNMENT LOT 2 SECTION 35 TOWNSHIP 37 SOUTH RANGE 41 EAST, LYING IMMEDIATELY SOUTH OF THE NORTH 200 FEET OF SAID GOVERNMENT LOT 2 AND DESCRIBED AS BEGINNING AT THE POINT OF INTERSECTION OF THE EAST RIGHT-OF-WAY LINE OF SEWALLS POINT ROAD WITH THE SOUTH LINE OF SAID NORTH 200 FOOT PARCEL, THENCE SOUTHERLY WITH THE SAID EAST RIGHT-OF-WAY LINE OF SAID SEWALLS POINT ROAD NINETY FEET TO A POINT THENCE EAST ON A LINE PARALLEL WITH THE SOUTH LINE OF SAID NORTH 200 FEET PARCEL TO THE EAST BOUNDARY LINE OF SAID GOVERNMENT LOT 2 TO THE POINT WHERE THE SAID SOUTH LINE OF SAID NORTH 200 FOOT PARCEL INTERSECTS THE SAID EAST BOUNDARY LINE OF SAID GOVERNMENT LOT 2 THENCE WEST ALONG THE SOUTH LINE OF THE NORTH 200 FOOT PARCEL TO THE POINT OF BEGINNING

TOGETHER WITH THE EASEMENT AND APPURTENANT RIGHTS SET FORTH IN DEED RECORDED IN DEED BOOK 48 PAGE 205 MARTIN COUNTY FLORIDA PUBLIC RECORDS

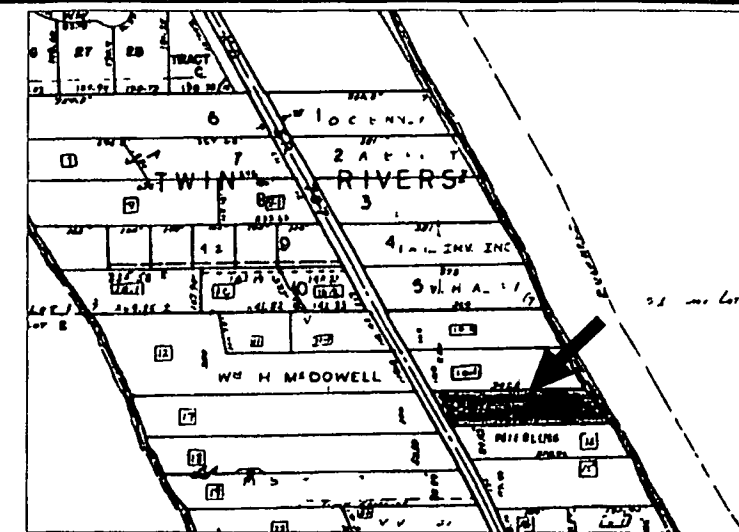

LOCATION MAP

REVISIONS	BY
NEW BENCHMARK	ASA
1/20/06	ASA
RAISED DRAINAGE	ASA
2/15/06	ASA
F.F. ELEV	SJB
5/23/06	SJB
REVISED SITE PLAN	ASA
7/12/06	ASA
8/1/06	SJB
ELEV. INFO	SJB

STEPHEN J BROWN, INC
 LICENSED BUSINESS NUMBER 6484
 SURVEYORS • DESIGNERS • LANDPLANNERS • CONSULTANTS
 619 EAST 5TH STREET STUART FLORIDA 34984
 (772) 288 7176

BOUNDARY SURVEY
 PREPARED FOR GRAHAME

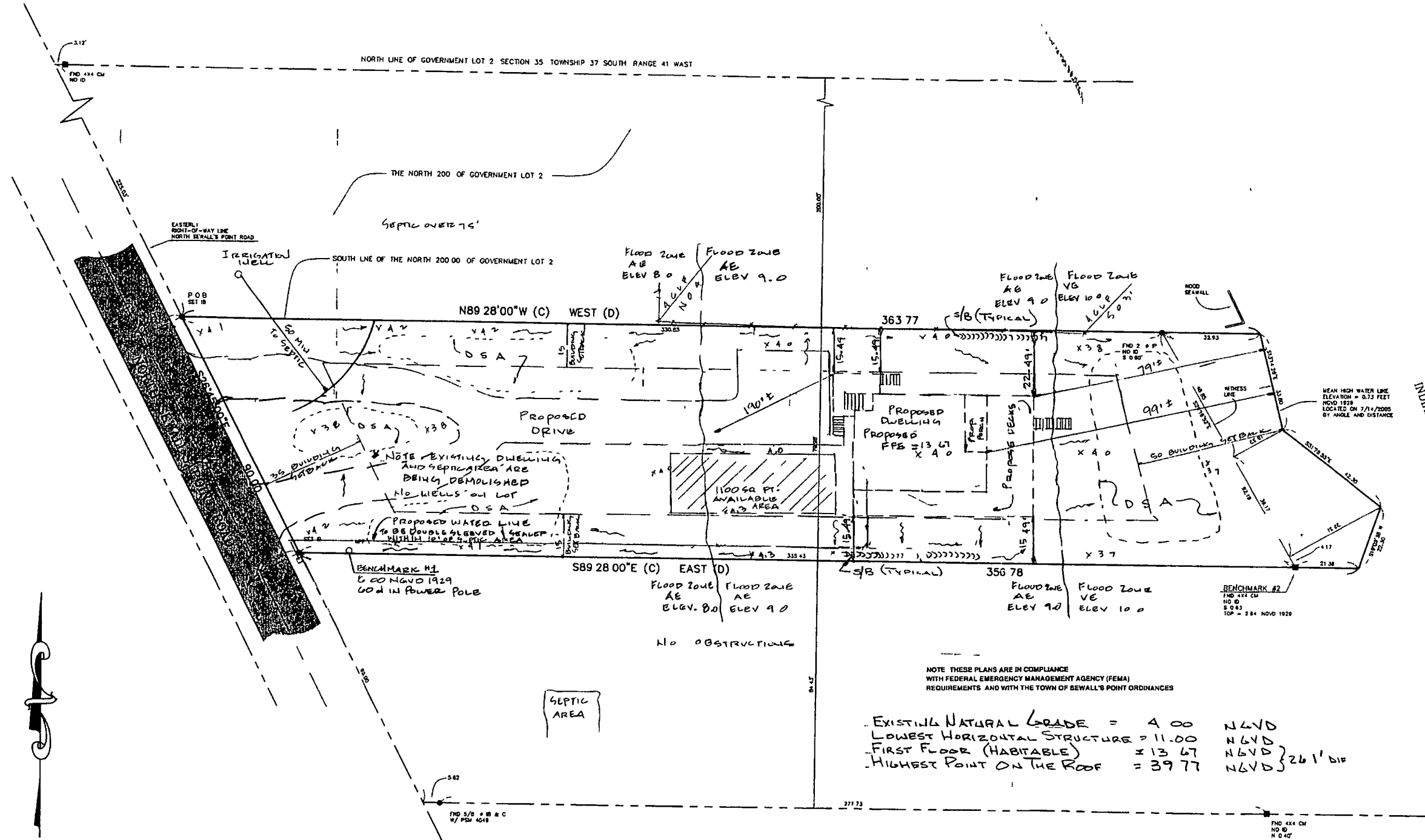

TOTAL LOT = 28,752 SQ FT - 100%
 BUILDING AREA = 2,307 SQ FT - 8%
 TOTAL IMPROVEMENTS = 6,507 SQ FT - 22.6%

EXISTING NATURAL GRADE = 4.00 NLVD
 LOWEST HORIZONTAL STRUCTURE = 11.00 NLVD
 FIRST FLOOR (HABITABLE) = 13.67 NLVD
 HIGHEST POINT ON THE ROOF = 39.77 NLVD } 26' DIA

THE MEAN HIGH WATER SURVEY DEPICTED HEREON COMPLES WITH CHAPTER 177 PART II FLORIDA STATUTES AND IS RECORDED IN THE PUBLIC RECORDS OF THE FLORIDA DEPARTMENT OF ENVIRONMENTAL PROTECTION BUREAU OF SURVEYING AND MAPPING AS MEAN HIGH WATER SURVEY FILE NO 3654

ELEVATIONS INDICATED HEREON ARE IN FEET AND DECIMALS REFERENCED TO NGVD 1929

DRAINAGE = 3.6, 507 X 21.5, 366 C/F STORAGE
 D.S.A = DRAINAGE STORAGE AREA TO BE DEPRESSED 6" TO 12" BELOW FINAL GRADE
 S/B = SWALE OR BERM TO DIRECT RUNOFF TO D.S.A

AC	ACRE	EDP	EDGE OF PAVEMENT	N & T	MAIL & TIN TAB	PRO	PROBATED
A/C	AIR CONDITIONER	EW	EDGE OF WATER	N & W	MAIL & WASHER	PR	PRAISE
ALUM	ALUMINUM	EM	ELECTRIC METER	NO & D	NATIONAL GEODETIC VERTICAL DATUM	RAD	RADIAL
AND	ANCHOR	EN	ELECTRIC SERVICE	NO & D	NO DISTORTION	RAD	RADIUS
APPROX	APPROXIMATE	ELEV	ELEVATION	NTS	NOT TO SCALE	RANG	RANGE
AS	ARCADE	ENC	ENCLOSURE	ONS	OFFICIAL RECORD BOOK	REG	REGISTERED LAND SURVEYOR
ASB	ASBESTOS	ENCL	ENCLOSURE	OPT	OFFSET	RES	REINFORCED CONCRETE PIPE
BK	BACK	ET	EXISTING ELEVATION	OS	OVERHEAD	R/W	RIGHT OF WAY
BK	BOULEVARD	FT	FEET	OS	OFFSET	SEC	SECTION
BLD	BUILDING	FS	FENCED FLOOR ELEVATION	ON	OVERHEAD WIRE	SECT	SECTION
BLD	BUILDING	FS	FENCED FLOOR ELEVATION	ON	OVERHEAD WIRE	SECT	SECTION
BLD	BUILDING	FS	FENCED FLOOR ELEVATION	ON	OVERHEAD WIRE	SECT	SECTION
BLD	BUILDING	FS	FENCED FLOOR ELEVATION	ON	OVERHEAD WIRE	SECT	SECTION

- PROPERTY ADDRESS 102 NORTH SEWALLS POINT ROAD
- CERTIFIED TO PETER GRAHAME

NOT VALID WITHOUT THE SIGNATURE AND THE ORIGINAL RAISED SEAL OF A FLORIDA LICENSED SURVEYOR AND MAPPER

STEPHEN J BROWN INC

THE TOWN OF SEWALLS POINT

STEPHEN J BROWN PROFESSIONAL SURVEYOR AND MAPPER
 REGISTRATION NO 4049 STATE OF FLORIDA

NOTES
 1 Survey of description as furnished by Client
 2 Lands shown hereon were not abstracted for easements and/or rights-of-way of record
 3 All bearings are referenced to the centerline of North Sewalls Point Road assumed as S26 45 00"W all others relative thereto
 4 Elevations shown hereon are relative to National Geodetic Vertical Datum of 1929 and are based on bench mark
 5 There are no above ground encroachments unless otherwise shown
 6 The National Flood Insurance Program designation as indicated on the FEMA Map No 12085-D-584 dated 10/04/2002, locates the parcel in Zone AE-XE - base flood elevation 8.9 & 10 - feet subject to any scaling and interpolation factors associated with mapping of this accuracy This data is an interpretation by the surveyor and is provided as a courtesy The flood zone(s) should be verified by a determination agency
 7 Underground foundations & utilities not located unless shown

DRAWN	SJB
CHECKED	SJB
DATE	01/06/2006
SCALE	1" = 20'
JOB NO	2120-02-01
SHEET	ONE
OF ONE	SHEETS

PROPOSED

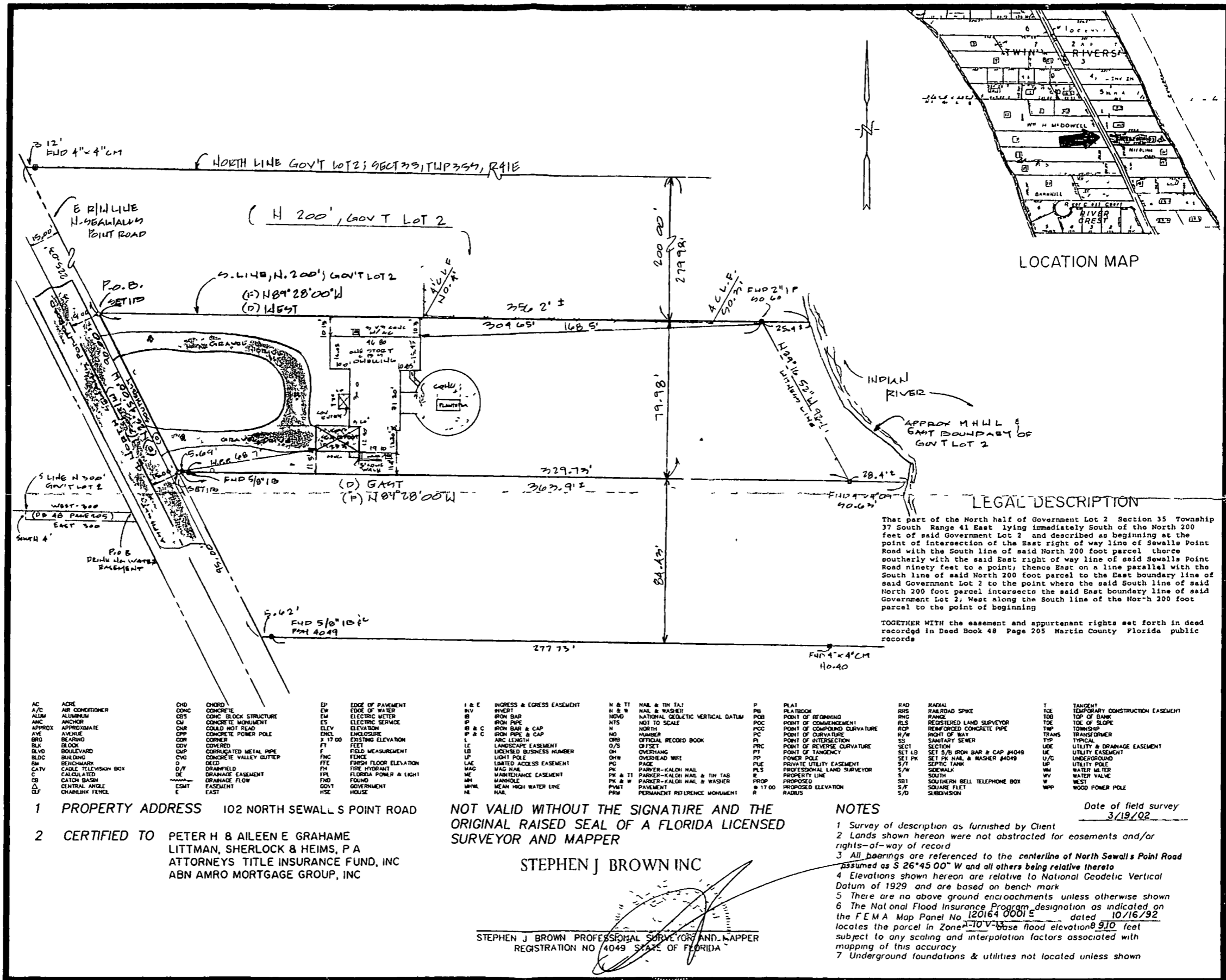

REVISIONS	BY

BOUNDARY SURVEY
PREPARED FOR GRAHAME

STEPHEN J BROWN, INC
SURVEYORS • DESIGNERS • LANDPLANNERS • CONSULTANTS
619 EAST 5TH STREET, STUART, FLORIDA 34994

LICENSED BUSINESS NUMBER 6484
(561) 288-7176

LEGAL DESCRIPTION

That part of the North half of Government Lot 2 Section 35 Township 37 South Range 41 East lying immediately South of the North 200 feet of said Government Lot 2 and described as beginning at the point of intersection of the East right of way line of Sewalls Point Road with the South line of said North 200 foot parcel three eighths of the said East right of way line of said Sewalls Point Road ninety feet to a point; thence East on a line parallel with the South line of said North 200 foot parcel to the East boundary line of said Government Lot 2 to the point where the said South line of said North 200 foot parcel intersects the said East boundary line of said Government Lot 2; West along the South line of the North 200 foot parcel to the point of beginning

TOGETHER WITH the easement and appurtenant rights set forth in deed recorded in Deed Book 48 Page 205 Martin County Florida public records

AC A/C	ACRE AIR CONDITIONER	CHD CHDC	CHORD CONCRETE CONIC BLOCK STRUCTURE	EP EW	EDGE OF PAVEMENT EDGE OF WATER	I & E INV	INGRESS & EGRESS EASEMENT INVERT	N & TT N & W	NAIL & TIN TAB NAIL & WASHER NATIONAL GEODETIC VERTICAL DATUM	P	PLAT	RAD	RADIAL	T	TANGENT
ALM	ALUMINUM	CS	CONCRETE MONUMENT	ES	ELECTRIC SERVICE	IB	IRON BAR	NS	NOT TO SCALE	PB	POINT OF BEGINNING	RNS	RANGE	TOE	TEMPORARY CONSTRUCTION EASEMENT
ANC	ANCHOR	CU	CULVERT	ELEV	ELEVATION	IB & C	IRON BAR & CAP	NTS	NORTH	POB	POINT OF BEGINNING	RLS	REGISTERED LAND SURVEYOR	TDE	TIDE OF SLOPE
APPROX	APPROXIMATE	COUR	CONCRETE POWER POLE	ENCL	ENCLOSURE	P & C	IRON PIPE & CAP	N	NORTH	PCC	POINT OF CURVATURE	RCR	REINFORCED CONCRETE PIPE	TWP	TOWNSHIP
AV	AVENUE	OP	CONCRETE VALLEY CUTTER	FT	FEET	L	LANDSCAPE EASEMENT	NO	NUMBER	PC	POINT OF CURVATURE	R/W	RIGHT OF WAY	TRANS	TRANSFORMER
BRD	BEARING	COR	CORNER	X 17 00	EXISTING ELEVATION	L	LANDSCAPE EASEMENT	ORF	OFFICIAL RECORDED BOOK	PI	POINT OF INTERSECTION	SS	SANITARY SEWER	TYP	TYPICAL
BLK	BLOCK	COV	CONCRETE	FEET	FIELD MEASUREMENT	LE	LANDSCAPE EASEMENT	O/S	OVERHEAD	PRC	POINT OF REVERSE CURVATURE	SECT	SECTION	UTE	UTILITY & DRAINAGE EASEMENT
BLVD	BOULEVARD	CONP	CONCRETE POWER POLE	FT	FEET	LB	LICENSED BUSINESS NUMBER	OH	OVERHEAD WIRE	PT	POINT OF TANGENCY	SET LB	SET 1/8" IRON BAR & CAP #1049	UE	UTILITY EASEMENT
BLDG	BUILDING	CVC	CONCRETE VALLEY CUTTER	FNC	FENCE	LP	LIGHT POLE	OHW	OVERHEAD WIRE	PP	POWER POLE	SET PK	SET 1/4" NAIL & WASHER #1049	U/G	UNDERGROUND
BM	BENCHMARK	DE	DRAINAGE EASEMENT	FTE	FRESH FLOOR ELEVATION	LAE	LIMITED ACCESS EASEMENT	PA	PAGE	PUE	PRIVATE UTILITY EASEMENT	S/T	SEPTIC TANK	UP	UTILITY POLE
CATV	CABLE TELEVISION BOX	D	DRAINAGE EASEMENT	FN	FIRE HYDRANT	LAG	LANDSCAPE EASEMENT	PK	PARKER-KALOH NAIL	PLS	PROFESSIONAL LAND SURVEYOR	S/W	SIDEWALK	WM	WATER METER
C	CALCULATED	DE	DRAINAGE EASEMENT	FPL	FLORIDA POWER & LIGHT	LAG	LANDSCAPE EASEMENT	PK & TT	PARKER-KALOH NAIL & TIN TAB	R	PROPERTY LINE	S	SOUTH	WV	WATER VALVE
CB	CATCH BASIN	DE	DRAINAGE EASEMENT	FND	FINDING	LAG	LANDSCAPE EASEMENT	PK & W	PARKER-KALOH NAIL & WASHER	PROP	PROPOSED	S/S	SOUTHERN BELL TELEPHONE BOX	W	WEST
CA	CENTRAL ANGLE	ESMT	EASEMENT	FND	FINDING	LAG	LANDSCAPE EASEMENT	PVMT	PAVEMENT	PROP	PROPOSED	S/S	SOUTHERN BELL TELEPHONE BOX	W	WEST
CLF	CHARLIE FENCE	E	EAST	HSE	HOUSE	LAG	LANDSCAPE EASEMENT	NE	NAIL	R	RADIUS	S/D	SUBDIVISION	WPP	WOOD POWER POLE

- PROPERTY ADDRESS 102 NORTH SEWALL S POINT ROAD
- CERTIFIED TO PETER H & AILEEN E GRAHAME LITTMAN, SHERLOCK & HEIMS, P A ATTORNEYS TITLE INSURANCE FUND, INC ABN AMRO MORTGAGE GROUP, INC

NOT VALID WITHOUT THE SIGNATURE AND THE ORIGINAL RAISED SEAL OF A FLORIDA LICENSED SURVEYOR AND MAPPER

STEPHEN J BROWN INC

STEPHEN J BROWN PROFESSIONAL SURVEYOR AND MAPPER
REGISTRATION NO 4049 STATE OF FLORIDA

- NOTES**
- Survey of description as furnished by Client
 - Lands shown hereon were not abstracted for easements and/or rights-of-way of record
 - All bearings are referenced to the centerline of North Sewalls Point Road assumed as S 26°45'00" W and all others being relative thereto
 - Elevations shown hereon are relative to National Geodetic Vertical Datum of 1929 and are based on bench mark
 - There are no above ground encroachments unless otherwise shown
 - The National Flood Insurance Program designation as indicated on the FEMA Map Panel No 120164 0001 E dated 10/16/92 locates the parcel in Zone A-10 V-base flood elevation 9.10 feet subject to any scaling and interpolation factors associated with mapping of this accuracy
 - Underground foundations & utilities not located unless shown

Date of field survey 3/19/02

DRAWN	SJB
CHECKED	SJB
DATE	3/19/02
SCALE	1" = 30'
JOB NO	2120-02-01
SHEET	ONE
of ONE SHEETS	

EXISTING

TOWN OF SEWALL'S POINT

Building Department - Inspection Log

Date of Inspection: Monday Tuesday Wednesday Thursday Friday Saturday Sunday, 2001; Page 2 of 2.

PERMIT	OWNER/ADDRESS/CONTR	INSPECTION TYPE	RESULTS	NOTES/COMMENTS
✓ 5280	ROTHBERG	RTG. WALL	Passed	Also die back
N (6)	1123 N. SEWALLS POINT RD CUSTOM BUILT MARINE (GRAMM)	TERACES		INSPECTOR 7/13
PERMIT	OWNER/ADDRESS/CONTR	INSPECTION TYPE	RESULTS	NOTES/COMMENTS
✓ 5358	INGRAM	GARAGE -	Passed	
N (8)	101 N. SEWALLS POINT RD. BIFORD CONST. (ANDY)	TIE BM.		INSPECTOR 7/18
PERMIT	OWNER/ADDRESS/CONTR	INSPECTION TYPE	RESULTS	NOTES/COMMENTS
✓ 5444	SEBASTIANO	RTG. WALL -	Passed	
N (9)	99 N. SEWALLS POINT RD. BIFORD CONST. (ANDY)	FTG.		INSPECTOR 7/18
PERMIT	OWNER/ADDRESS/CONTR	INSPECTION TYPE	RESULTS	NOTES/COMMENTS
✓ 5409	HELLER	PORCH REPAIR -	Passed	
S (1)	23 N. VIA LUCINDA TREAS. COAST CARPENTRY	FINAL		INSPECTOR 7/18
PERMIT	OWNER/ADDRESS/CONTR	INSPECTION TYPE	RESULTS	NOTES/COMMENTS
✓ T/R	CARY	FIELD VERIF.	Passed	288 4792
S (2)	76 S. RIVER RD @ VIA LUCINDA GONZALEZ			INSPECTOR 7/18
PERMIT	OWNER/ADDRESS/CONTR	INSPECTION TYPE	RESULTS	NOTES/COMMENTS
✓ T/R	KIRLINGER WASHINGTON	FIELD VERIF.	Passed	
S (11)	143 S. RIVER RD O/B (EARL PEARSON 287-4011)			INSPECTOR 7/18
PERMIT	OWNER/ADDRESS/CONTR	INSPECTION TYPE	RESULTS	NOTES/COMMENTS
✓ 5439	BRENNAN	STL. & GROUND	Passed	FORMBOARD SURVEY
S (3)	111 HENRY SEWALL WAY FLAMINGO POOLS			WAIVED. 7/18 ✓ INSPECTOR 7/18

OTHER _____

TOWN OF SEWALL'S POINT

Building Department - Inspection Log

Date of Inspection: Mon Wed Fri ~~August 2001~~, 2001; Page 1 of 1.

PERMIT	OWNER/ADDRESS/CONTR	INSPECTION TYPE	RESULTS	NOTES/COMMENTS
✓ S 5447	BARLAND 1 VIA LUCINDIA HARBOR BAY POOLS 878 8806	STC./MAIN DRAIN	Failed Washout	FORM BOARD(S) SOAKY WASHED Called contractor INSPECTOR <i>[Signature]</i> 8/6
✓ S 5302	NOHE JL 6 N. RIDGEVIEW RD RAYMOND CONST.	FRAMING - ALL TRADES	Passed (1 Strap +	(All enclosure!) Roaming pencils.) INSPECTOR <i>[Signature]</i> 8/6
✓ S 5426	DEMOREST 925. RIVER ROAD COMMERCIAL CONST.	ENTRY ENCL. - SLAB	Passed	INSPECTOR <i>[Signature]</i> 8/6
✓ N 5143	GIFFORD 85 N. SEWALL'S POINT RD SCOTT J. HOLMES, BLDG. INC	LATH	Passed	INSPECTOR <i>[Signature]</i> 8/6
✓ N 5280	ROTHBERG 103 N. SEWALL'S POINT RD CUSTOM BUILT MARLINE	CEILING/RIP RAP Rinal → (288-4254)	Passed Passed	INSPECTOR <i>[Signature]</i> 8/6
✓ N 5443	WYEKOFF 26 N. RIVER ROAD O/B	WALL RTG.	Passed	See owner INSPECTOR <i>[Signature]</i> 8/6
5466	Matuszewski 3 Miramar A+P Bldg.	Shedding roof	Passed	INSPECTOR <i>[Signature]</i> 8/6

OTHER *[Stamp]* VERIFY FLOOD DEBRIS CLEAN-UP: ~~1735 RIVER RD~~ 295. RIVER RD (PN 4978)
(REINSPECTION) RIVER-LEAK DEVELOPMENT.
Cleanup in progress *[Signature]* 8/6

7308

DOCK REPAIR

MASTER PERMIT NO. _____

TOWN OF SEWALL'S POINT

Date 2/14/05

BUILDING PERMIT NO. 7308

Building to be erected for ROTHBERG

Type of Permit DOCK REPAIR

Applied for by CUSTOM DECKS INC

(Contractor) Building Fee 240.00

Subdivision LOUIT LOT Lot PAR 2 Block _____

Radon Fee _____

Address 103 N. SEWALL'S POINT RD

Impact Fee _____

Type of structure SFR

A/C Fee _____

Parcel Control Number

Electrical Fee _____

3537410 00 00000 12070000

Plumbing Fee _____

Amount Paid 264.00 Check # _____ Cash _____

Roofing Fee _____

10% PLAN REVIEW 24.00

Total Construction Cost \$ 12,500.00

TOTAL Fees 264.00

Signed Bill Mathews

Signed Gene Simmons (RSD)

Applicant

Town Building Official

PERMIT

- BUILDING
- PLUMBING
- DOCK/~~BOAT LIFT~~
- SCREEN ENCLOSURE
- FILL
- TREE REMOVAL

- ELECTRICAL
- ROOFING
- DEMOLITION
- TEMPORARY STRUCTURE
- HURRICANE SHUTTERS
- STEMWALL

- MECHANICAL
- POOL/SPA/DECK
- FENCE
- GAS
- RENOVATION
- ADDITION

INSPECTIONS

- UNDERGROUND PLUMBING _____
- UNDERGROUND MECHANICAL _____
- STEMWALL FOOTING _____
- SLAB _____
- ROOF SHEATHING _____
- TRUSS ENG/WINDOW/DOOR BUCKS _____
- ROOF TIN TAG/METAL _____
- PLUMBING ROUGH-IN _____
- MECHANICAL ROUGH-IN _____
- FRAMING _____
- FINAL PLUMBING _____
- FINAL MECHANICAL _____
- FINAL ROOF _____

- UNDERGROUND GAS _____
- UNDERGROUND ELECTRICAL _____
- FOOTING _____
- TIE BEAM/COLUMNS _____
- WALL SHEATHING _____
- LATH _____
- ROOF-IN-PROGRESS _____
- ELECTRICAL ROUGH-IN _____
- GAS ROUGH-IN _____
- EARLY POWER RELEASE _____
- FINAL ELECTRICAL _____
- FINAL GAS _____
- BUILDING FINAL _____

Feb 03 05 05:16 PM
Feb 03 05 05:16 PM
BY: [Signature]

SERENA MAGI
Lobloilly -

5615862432
772 546 3897

P. 3
P. 3

Town of Sewall's Point
BUILDING PERMIT APPLICATION

Date 02-14-05 Permit Number _____

OWNERTITLEHOLDER NAME Hemphill Trust Phone (Day) _____ (Fax) _____

JOB Site Address 103 N. SEWALL'S POINT Rd. City SEWALL'S POINT State FL Zip 34996

Legal Desc. Property (Subd/Lot/Block) PART OF EDU. LOT # 2 Parcel Number 353741000000001207

Owner Address (if different) _____ City _____ State _____ Zip _____

Description of Work To Be Done REBUILD DAMAGED PORTION OF EXISTING DOCK

WILL OWNER BE THE CONTRACTOR?

YES NO

COST AND VALUES

Estimated Cost of Construction or Improvements \$ 12,500
(Notice of Commencement needed over \$2500)
Estimated Fair Market Value prior to improvement \$ _____

Is Improvement cost 50% or more of Fair Market Value? YES NO

(If no, fill out the Contractor & Subcontractor sections below)

Method of Determining Fair Market Value _____

(If yes Owner Builder Affidavit must accompany application)

CONTRACTOR/Company CUSTOM DECKS INC. Phone 772-521-1726 Fax 772-220-4902

Street 2014 S.W. SUNSET TRAIL City PACON CITY State FL Zip 34990

State Registration Number _____ State Certification Number _____ Martin County License Number SP0-2950

SUBCONTRACTOR INFORMATION

Electrical N/A State _____ License Number _____
Mechanical _____ State _____ License Number _____
Plumbing _____ State _____ License Number _____
Roofing _____ State _____ License Number _____

ARCHITECT _____ Lic # _____ Phone Number _____
Street _____ City _____ State _____ Zip _____

ENGINEER N/A Lic # _____ Phone Number _____
Street _____ City _____ State _____ Zip _____

AREA SQUARE FOOTAGE - SEWER - ELECTRIC Living _____ Garage _____ Covered Patios _____ Screened Porch _____
Carport _____ Total Under Roof _____ Wood Deck 800-1000 SF DOCK Accessory Building _____

I understand that a separate permit from the Town may be required for ELECTRICAL PLUMBING MECHANICAL SIGNS POOLS WELLS FURNACE, BOILERS, HEATERS TANKS DOCKS SEA WALLS ACCESSORY BUILDING SAND OR FILL ADDITION OR REMOVAL AND TREE REMOVAL AND RELOCATIONS

CODE EDITIONS IN EFFECT AT TIME OF APPLICATION Florida Building Code (Structural, Mechanical, Plumbing, Gas) 2001
National Electrical Code 2002 Florida Energy Code 2001 Florida Accessibility Code 2001

I HEREBY CERTIFY THAT THE INFORMATION I HAVE FURNISHED ON THIS APPLICATION IS TRUE AND CORRECT TO THE BEST OF MY KNOWLEDGE AND I AGREE TO COMPLY WITH ALL APPLICABLE CODES, LAWS AND ORDINANCES DURING THE BUILDING PROCESS

OWNER OR AGENT SIGNATURE (required)
[Signature]
State of Florida County of PALM BEACH
This the 7 day of Feb, 2005
by Michael L. Rothberg/TLE who is personally known to me or produced

CONTRACTOR SIGNATURE (required)
[Signature]
On State of Florida County of MARTIN
This the 14th day of FEBRUARY 2005
by William Mathews who is personally known to me or produced
As identification [Signature]
Notary Public

as identification [Signature]
My Commission Expires Feb 21, 2005
My Commission Expires _____

My Commission Expires _____

PERMIT APPLICATIONS VALID 30 DAYS FROM APPROVAL NOTIFICATION - PLEASE PICK UP YOUR PERMIT
NOTARY PUBLIC
KATHA MARIE JONES
MY COMMISSION # CC 985700
EXPIRES February 21, 2005
Bonded Thru Notary Public Underwriters
NOTARY PUBLIC
LAURA O'BRIEN
MY COMMISSION # 268961
EXPIRES April 28, 2007
Bonded Thru Notary Public Underwriters



Department of Environmental Protection

Port St. Lucie Branch Office
1801 SE Hillmoor Dr. ve
Suite C-204

Jeb Bush
Governor

David B. Scrubs
Secretary

FILE COPY Port St. Lucie, FL 34952
(561) 398-2806

TOWN OF SEWALL'S POINT
THESE PLANS HAVE BEEN
REVIEWED FOR CODE COMPLIANCE

DATE 2/14/05

BUILDING OFFICIAL
Gene Simmons

22

REPAIR WORK FOR HURRICANE DAMAGE

File Number 43-0165717-002
Martin County

001 02 2000
Henry M. Rothberg
3218 NW 62nd Street
Boca Raton, FL 33416

Dear Mr. Rothberg

On September 26, 2000 we received your application for an exemption to perform the following activities: remove a 1,200 square foot boathouse and a 12.5' by 8' triangular platform, reduce the width of the access from 6' wide to 5' wide, construct a 24' by 5' terminal platform with an associated mooring area for a total of 995 square feet of structure in the St. Lucie River, Class III waters of the state located at 103 N. Sewalls Point Road (Section 35, Township 37 South, Range 41 East) Stuart, Martin County.

Your application has been reviewed to determine whether it qualifies for any of three kinds of authorization that may be necessary for works in wetlands or waters of the United States. The kinds of authorization are (1) regulatory authorization, (2) proprietary authorization (related to state-owned submerged lands), and (3) federal authorization. The authority for review and the outcomes of the reviews are listed below. Please read each section carefully. Your project may not have qualified for all three forms of authorization. If your project did not qualify for one or more of the authorizations, refer to the specific section dealing with that authorization for advice on how to obtain it.

1 Regulatory Review - EXEMPTION VERIFIED

The Department has the authority to review your project under Part IV of Chapter 373, Florida Statutes (F.S.), Title 62, Florida Administrative Code (F.A.C.), and in accordance with operating agreements executed between the Department and the water management districts, as referenced in Chapter 62-113, F.A.C.

Based on the information you submitted, we have determined that your project is exempt from the need to obtain a DEP Environmental Resource Permit under Rule 40E-4.051(3)(b), (F.A.C.)

2 Proprietary Review (related to state-owned lands) - GRANTED

The Department acts as staff to the Board of Trustees of the Internal Improvement Trust Fund (B.O.T.) and issues certain authorizations for the use of sovereign submerged lands. The Department has the authority to review your project under Chapters 253 and 258, F.S. Chapters 18-20 and 18-21, F.A.C., and Section 62-343.075, F.A.C.

Your project may occur on sovereign submerged land and may require authorization from the Board of Trustees to use public property. As staff to the Board of Trustees, we have reviewed the proposed project and have determined that, as long as it is located within the described boundaries and is consistent with the attached general consent conditions, the project qualifies for consent to use sovereign submerged lands. Therefore, pursuant to Chapter 253.77, Florida Statutes, you may consider this letter as authorization from the Board of Trustees for the upland riparian owner to perform the project.

12/14/00 TOWN OF SEWALL'S POINT
REVIEWED: [Signature]
BUDG. OFFICIAL

"More Protection Less Process"

Printed on recycled paper

PD _____

FILE TOWN COPY
103 N. SEWALLS PT. RD

3 Federal Review (State Programmatic General Permit) - AUTHORIZATION GRANTED

Federal authorization for the proposed project is reviewed by DEP pursuant to an agreement between the Department and the U.S. Army Corps of Engineers (the Corps). The agreement is outlined in a document titled *Coordination Agreement Between the U.S. Army Corps of Engineers and the Florida Department of Environmental Protection State Programmatic General Permit, Section 10 of the Rivers and Harbor Act of 1899 and Section 404 of the Clean Water Act*.

Your project has been reviewed for compliance with a State Programmatic General Permit (SPGP). Your proposed activity as outlined on the attached drawings is in compliance with the SPGP program. U.S. Army Corps of Engineers (Corps) General conditions apply to your project, as attached. **No further permitting for this activity is required by the Corps.** The authority granted under this SPGP expires December 17, 2003. Your project must be completed prior to this expiration date.

The determinations in this letter are based solely on the information provided to the Department and on the statutes and rules in effect when the application was submitted. The determinations are effective only for the specific activity proposed. These determinations shall automatically expire if site conditions materially change or if the governing statutes or rules are amended. In addition, any substantial modifications in your plans should be submitted to the Department for review, as changes may result in a permit being required. In any event, this determination shall expire after one year.

This letter does not relieve you from the responsibility of obtaining other permits (federal, state, or local) that may be required for the project.

NOTICE OF RIGHTS OF SUBSTANTIALLY AFFECTED PERSONS

This letter acknowledges that the proposed activity is exempt from ERP permitting requirements under Rule 40E-4.051(3)(b), F.A.C. This determination is final and effective on the date filed with the Clerk of the Department unless a sufficient petition for an administrative hearing is timely filed under sections 120.569 and 120.57 of the Florida Statutes as provided below. If a sufficient petition for an administrative hearing is timely filed, this determination automatically becomes only proposed agency action subject to the result of the administrative review process. Therefore, on the filing of a timely and sufficient petition, this action will not be final and effective until further order of the Department. The procedures for petitioning for a hearing are set forth in the attached notice.

This determination is based on the information you provided the Department and the statutes and rules in effect when the application was submitted and is effective only for the specific activity proposed. This determination shall automatically expire if site conditions materially change or the governing statutes or rules are amended. In addition, any substantial modifications in your plans should be submitted to the Department for review, as changes may result in a permit being required. In any event, this determination shall expire after one year.

Be advised that your neighbors and other parties who may be substantially affected by the proposed activity allowed under this determination of exemption have a right to request an administrative hearing on the Department's decision that the proposed activity qualifies for this exemption. Because the administrative hearing process is designed to redetermine final agency action on the application, the filing of a petition for an administrative hearing may result in a final determination that the proposed activity is not authorized under the exemption established under Rule 40E-4.051(3)(b), F.A.C.

Henry M Rothberg
File Number 43-0165717-002
Page Three

The Department will not publish notice of this determination. Publication of this notice by you is optional and is not required for you to proceed. However, in the event that an administrative hearing is held and the Department's determination is reversed, proceeding with the proposed activity before the time period for requesting an administrative hearing has expired would mean that the activity was conducted without the required permit.

If you wish to limit the time within which all substantially affected persons may request an administrative hearing, you may elect to publish, at your own expense, the enclosed notice (Attachment A) in the legal advertisement section of a newspaper of general circulation in the county where the activity is to take place. A single publication will suffice.

If you wish to limit the time within which any specific person(s) may request an administrative hearing, you may provide such person(s), by certified mail, a copy of this determination, including Attachment A.

For the purposes of publication, a newspaper of general circulation means a newspaper meeting the requirements of sections 50.011 and 50.031 of the Florida Statutes. In the event you do publish this notice, within seven days of publication, you must provide to the following address proof of publication issued by the newspaper as provided in section 50.051 of the Florida Statutes. If you provide direct written notice to any person as noted above, you must provide to the following address a copy of the direct written notice.

Florida Department of Environmental Protection, Southeast District - Port St. Lucie Branch Office
Submerged Lands & Environmental Resources Program, 1801 SE Hillmoor Drive Suite C-204
Port St. Lucie, FL 34952

Thank you for applying to the Submerged Lands and Environmental Resource Program. If you have questions regarding this matter, please contact **Danna Civetti** of this office, at telephone number (561)398-2806.

Sincerely,

Danna Civetti

f Gary N. Roderick
Environmental Administrator

GNR:DC *ps*

Enclosures: General Consent Conditions
Federal General/Specific Conditions for SPGP III- R1 and Transfer Request
Federal Manatee Conditions
Attachment A- Notice of Determination of Qualification for Exemption
Attachment D- General Single-Family Dock Information

cc U.S. Army Corps of Engineers, Stuart [without enclosures]
Custom Built Marine Construction, Inc. (Agent) [without enclosures]

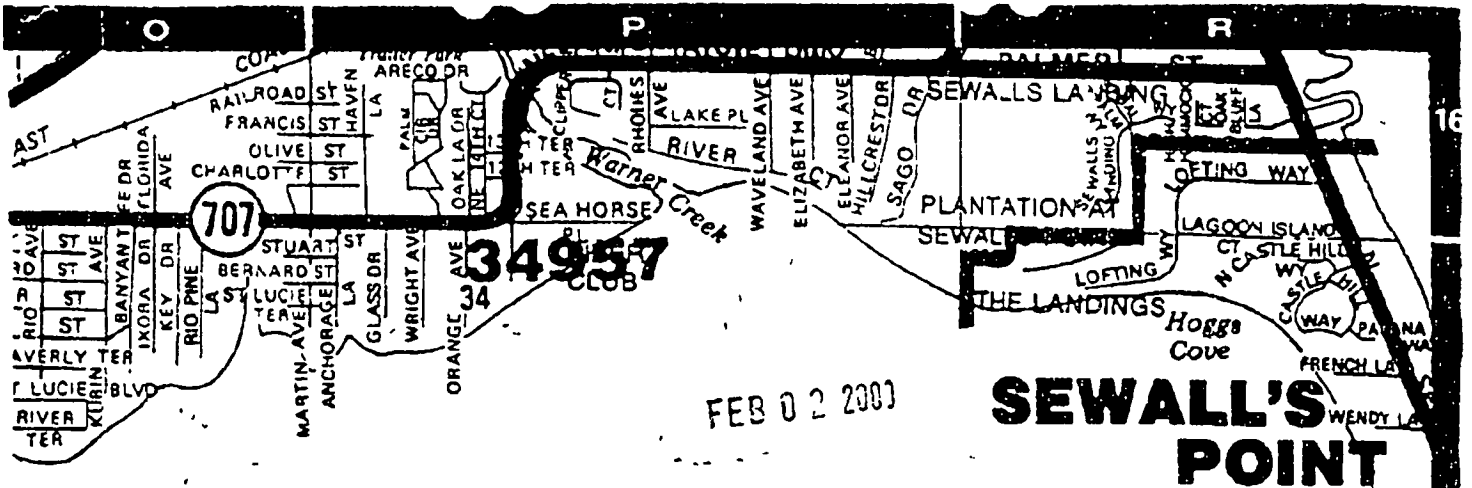

SEWALL'S POINT

Job Site:
103 N. Sewalls
Point Rd
Rothberg

DEPARTMENT OF ENVIRONMENTAL PROTECTION
STATE OF FLORIDA
43-01453-7
Rothberg
Sewall's Point
JUN 09 2000
A. C. Curtis

DEPARTMENT OF ENVIRONMENTAL PROTECTION
STATE OF FLORIDA
43-01453-7
Rothberg
Sewall's Point
JUN 09 2000
A. C. Curtis

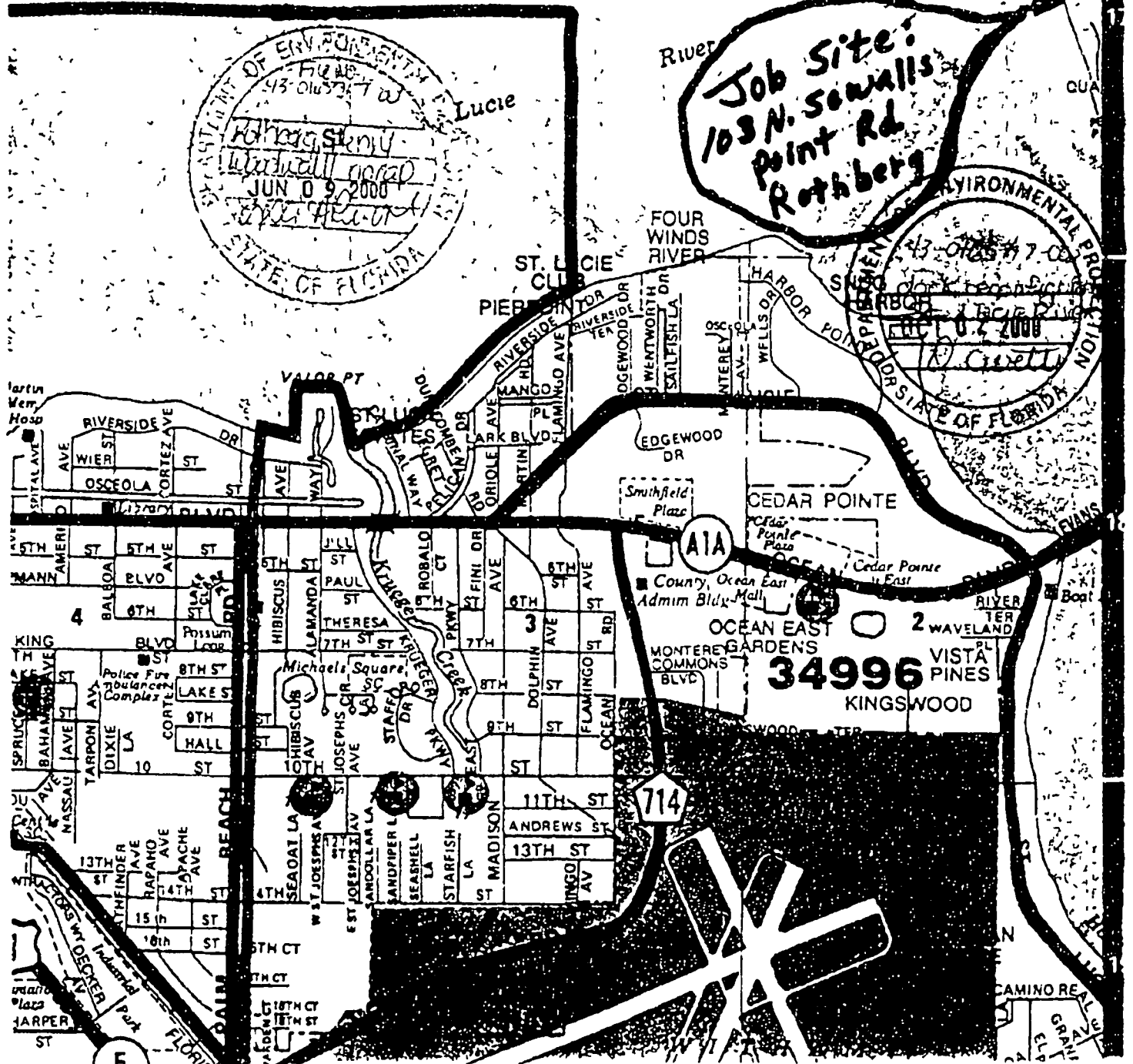

34996
KINGSWOOD

714

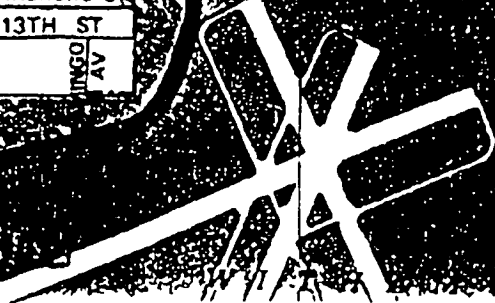

SEP 26 2000

Dept. of Environment Protection
Port St. Lucie
Hazardous Waste Division

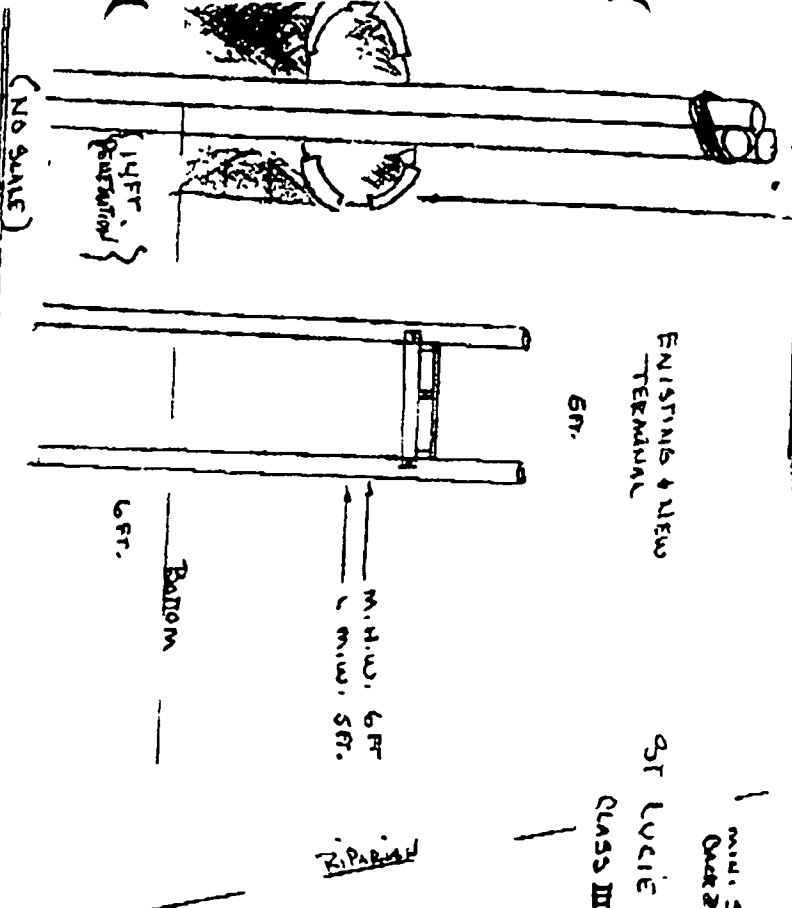

ST LUCIE RIVER
CLASS III WATERS

MIN. SET
BACK 25' +

PLANTING TOLERANCE
BOOM OVERHANG

L.M.W. 5 FT.
11 M.W. 6 FT.

N

MOORING
AREA

CAUTION 12' DIA MOORINGS AT ALL
FAIR MOORING CABLES
2-12" DIA SPEC. INFRASTRUC.
MOORING PILES

NOTE: TOTAL REQUIREMENTS
DOCK WITH NEW 5' X 24' TERMINAL
PLATFORM IS (995 S.F.T.)

NOTE: DOCK ACCESS EXISTING
6 FT. WIDE REDUCE 5 FT. WIDE
PLATFORMS 175 S.F.T.

(SCALE 1"=40')

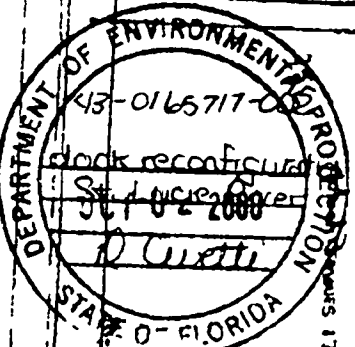

STROM BUILT MARINE CONSTRUCTION, INC.
10 S. SHADLER STREET
DADE CITY, FL 34907

HENRY ROTH BERG RESIDENCE
103 N. SEWALLS POINT ROAD
SEWALLS Pt. FL. 34994

PH: 561-298-4254

FAX: 561-298-2862

WEB SITE: WWW.CBMARINE.COM

SEC. 35 TWP. 37 SOUTH RANGE 41 EAST MARTIN COUNTY
RELOCATE EXISTING DOCK AND DOWNSIDE TO 995 S.F.T. TO
MINIMIZE DELIVER AND REC. EMPT PILES

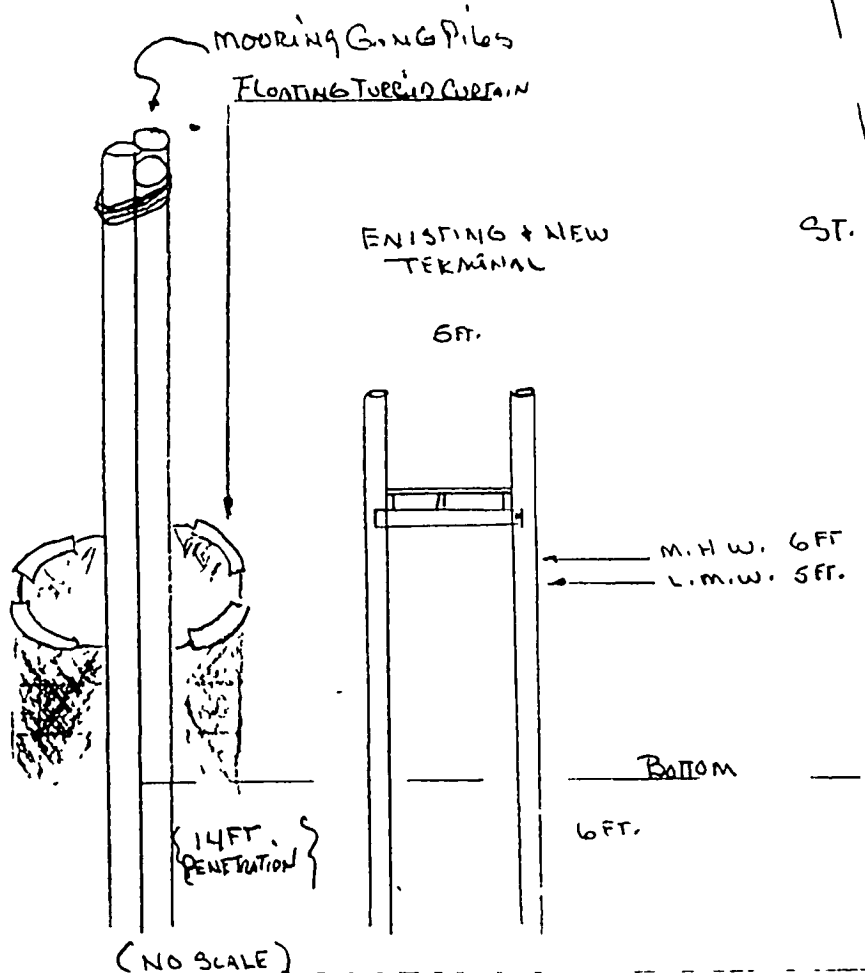

(NO SCALE)

CUSTOM BUILT MARINE CONSTRUCTION, INC.
 3170 S E WAALER STREET
 STUART, FL. 34997
 PHONE 561-288-4254
 FAX 561-288-2802
 WEBSITE WWW.CBMARINE.COM

ST. LUCIE RIVER
 CLASS III WATERS

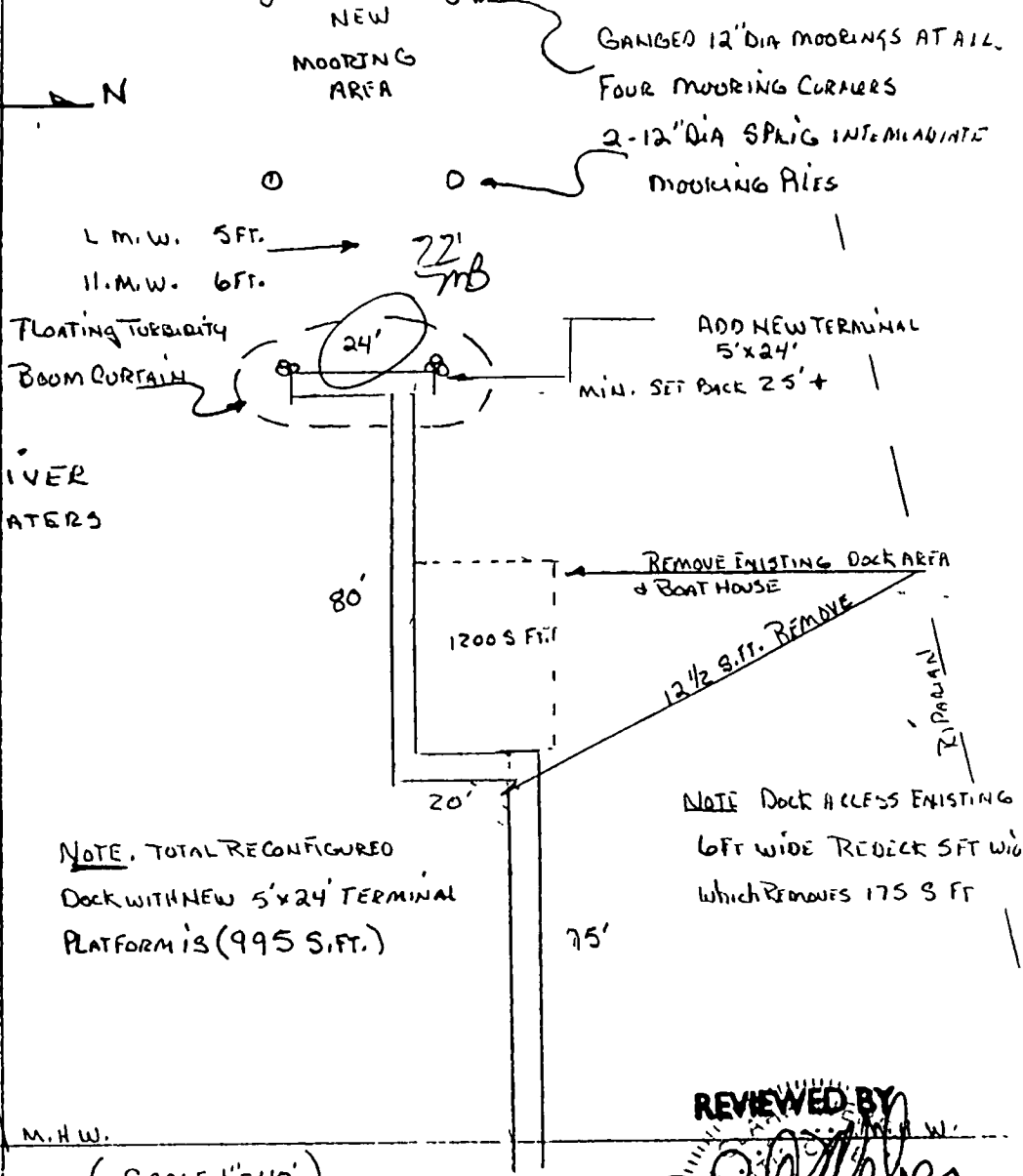

NOTE. TOTAL RECONFIGURED DOCK WITH NEW 5'x24' TERMINAL PLATFORM IS (995 S.F.T.)

NOTE DOCK ACCESS EXISTING 6 FT WIDE REDECK SFT WID WHICH REMOVES 175 S FT

M.H.W.

(SCALE) 1"=40'

HENRY ROTH BERG RESIDENCE
 103 N. SEWALLS POINT ROAD
 SEWALLS, FL. 34996
 SEC. 3.5 TWP. 37 SOUTH RANGE 4 EAST
 RECONFIGURE EXISTING DOCK AND DOWN SIZE TO 995 S.F.T. TO MINIMIZE CRITERIA AND PRE EMPY RISKS

REVIEWED BY

 OCT 16 2000
 FOR STATE OF FLORIDA
 DEPARTMENT OF ENVIRONMENTAL PROTECTION
 INTEGRITY

NEW TERMINAL PLATFORM 5'x24'

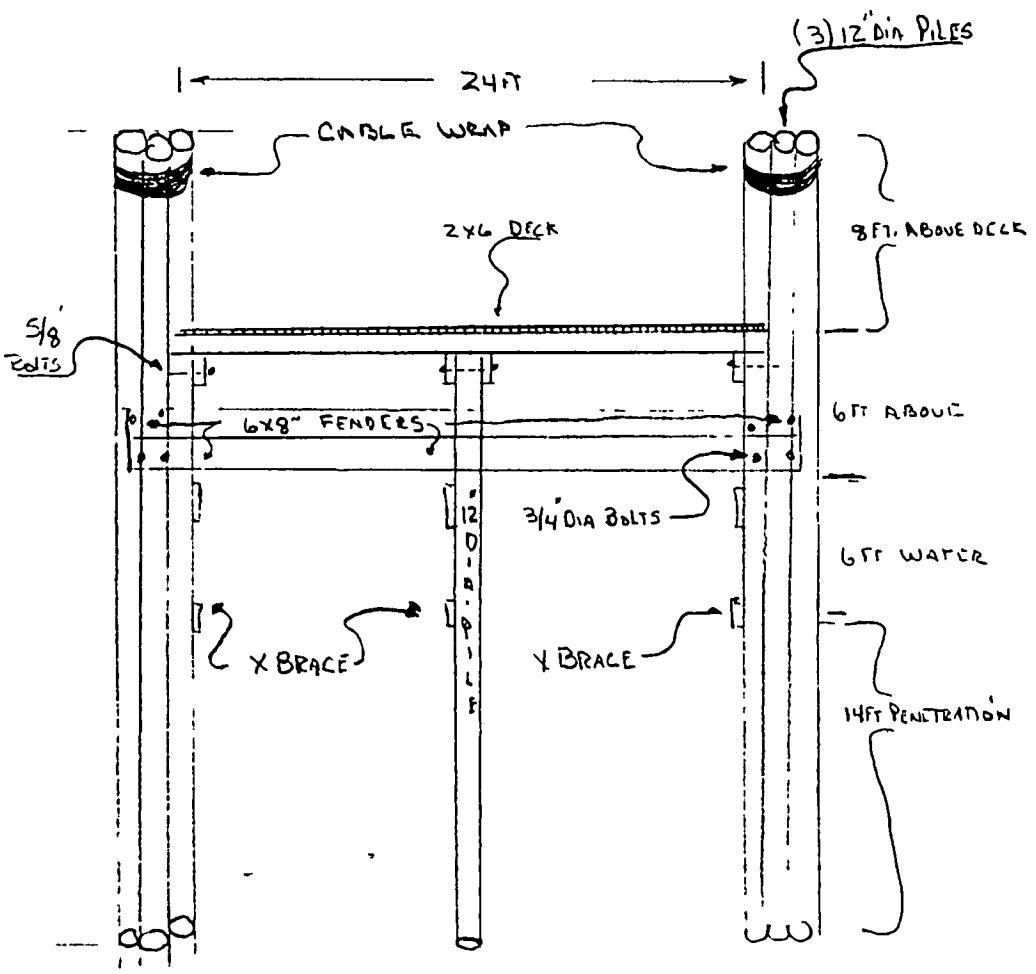

SCALE 1/8" = 1 FT.

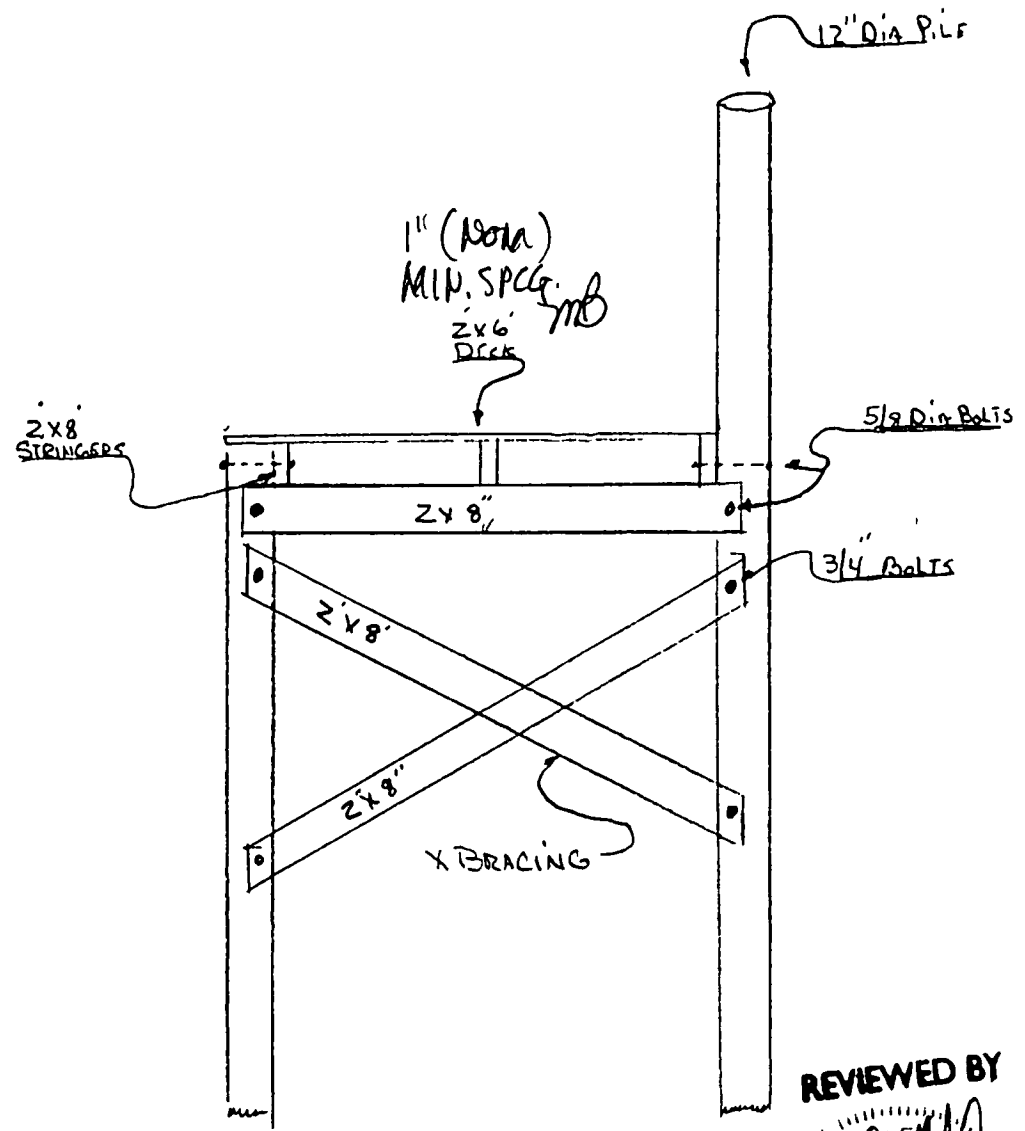

#20 SCALE

REVIEWED BY

[Signature]
 OCT 06 2000
 FOR STRUCTURAL INTEGRITY

CUSTOM BUILT MARINE CONSTRUCTION, INC.
 2110 S.E. WAALER STREET
 STUART, FL. 34997
 PHONE 561-288-4254
 FAX 561-288-2802

ROTHBERG RESIDENCE
 103 N. SEWALLS POINT ROAD
 SEWALLS POINT, FL. 34996
 PROPOSED TERMINAL DOCK 5' WIDE X 24' LONG
 WITH MOORING AND FENDER SYSTEM

WATER PUMP WITH COPIES



Notice of Commencement

To Whom It May Concern

The undersigned hereby informs all concerned that improvements will be made to certain real property and in accordance with section 713.13 of the Florida Statutes, the following information is stated in this NOTICE OF COMMENCEMENT

Legal Description of property (include street address if available)

103 N. SEWALL'S POINT Rd. (PART OF GOV. LOT #2)
PARCEL # 353.791 00000000 1207

General Description of improvements

REBUILD DAMAGED PORTION OF
EXISTING DOCK

Owner H.M. ROSE II TRUST

Address 7551 ISLA Verde way VERO BEACH, FL 33446

Owner's interest in site of the improvement OWNER 100%

Fee Simple Title holder (if other than owner)

Name

Address

Contractor CUSTOM DECKS BY BILL MATHEWS INC.

Address 2014 S.W. SUNSET TRAIL, PALM CITY FL.

Surety (if any) N/A

Address

Amount of bond \$

Any person making a loan for the construction of the improvements

Name

Address

Person within the State of Florida designated by owner upon who notices or other documents may be served

Name BILL MATHEWS 772-521-1726

Address 2014 S.W. SUNSET TRAIL PALM CITY, FL

In addition to himself, owner designates the following person to receive a copy of the Lienor's Notice as provided in Section 713.13 (1) (h), Florida Statutes (Fill in at Owner's Option)

Name

Address

This space for recorder's use only

[Signature]
Official

Sworn to and subscribed before me this 17
day of Feb 20 05

[Signature]

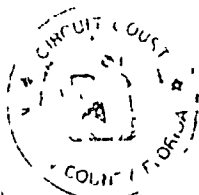

RECEIVED
FEB 03 2005
SERENA MAGI
2-14-05

INSTR # 1814479 OR BK 01982 PG 0520 RECD 02/14/2005 11 58 27 AM
MARSHA EMING MARTIN COUNTY DEPUTY CLERK S PHOENIX



TOWN OF SEWALL'S POINT

One South Sewall's Point Road

Sewall's Point, Florida 34996

(772) 287-2455

CORRECTION NOTICE

ADDRESS 103 N.S.P.R.

I have this day inspected this structure and these premises and have found the following violations of the City, County, and/or State laws governing same

POOR ELECTRIC

LIGHT FIXTURES, CABLES, RECEPTACLES
ETC. ARE NOT IN SERVICEABLE
CONDITION. EITHER BRING ALL
ELECTRIC UP TO CODE OR
REMOVE IT.

You are hereby notified that no work shall be concealed upon these premises until the above violations are corrected. When corrections have been made, call for an inspection.

DATE 7/18/07

INSPECTOR

DO NOT REMOVE THIS TAG

TOWN OF SEWALL'S POINT

Building Department - Inspection Log

Date of Inspection: Mon Wed Fri 7-18, 2007 Page 1 of 1

PERMIT	OWNER/ADDRESS/CONTR	INSPECTION TYPE	RESULTS	NOTES/COMMENTS
8441	Dressler	Temp Power Pole	PASS	Contacted FPL
1	12 Island Rd Harbor Course			INSPECTOR <i>[Signature]</i>

PERMIT	OWNER/ADDRESS/CONTR	INSPECTION TYPE	RESULTS	NOTES/COMMENTS
8566	Hepworth	Final	PASS	CLOSE
3	8 Rio Vista Keith Mahaffey	checked on comment re: tanks held shallow end		INSPECTOR <i>[Signature]</i>

PERMIT	OWNER/ADDRESS/CONTR	INSPECTION TYPE	RESULTS	NOTES/COMMENTS
7308	Rosinski (Clyde)	Final	FAIL	
5	103 N Sewalls Custom Decks	for electric is electric fixed? NO!		INSPECTOR <i>[Signature]</i>

PERMIT	OWNER/ADDRESS/CONTR	INSPECTION TYPE	RESULTS	NOTES/COMMENTS
8632	Gibson	Final	PASS	CLOSE
2	134 S River Rd Gulfstream Alum	fee PAID		INSPECTOR <i>[Signature]</i>

PERMIT	OWNER/ADDRESS/CONTR	INSPECTION TYPE	RESULTS	NOTES/COMMENTS
7495	DESANTIS	BOAT LIFT ELEC.	PASS	CLOSE
4	73. S RIVER			INSPECTOR <i>[Signature]</i>

PERMIT	OWNER/ADDRESS/CONTR	INSPECTION TYPE	RESULTS	NOTES/COMMENTS
66	LOT E OF 21 LANANA	MAINT		
				INSPECTOR

PERMIT	OWNER/ADDRESS/CONTR	INSPECTION TYPE	RESULTS	NOTES/COMMENTS
6829	Kearney	Final-	FAIL	
	12 N River JA Taylor	closure steps		INSPECTOR <i>[Signature]</i>

OTH: R/ -772-460-4040
 KAREN
 VIA DEL CRISTO



7308

TOWN OF SEWALL'S POINT

One South Sewall's Point Road
Sewall's Point, Florida 34996
(772) 287-2455

CORRECTION NOTICE

ADDRESS 103 N. S. P. R

I have this day inspected this structure and these premises and have found the following violations of the City, County, and/or State laws governing same

DOCK FINAL

ALL ELECTRICAL FIXTURES,
CABLES AND JUNCTION BOXES
ARE IN A STATE OF DISREPAIR
AND NEED TO BE BROUGHT
UP TO CODE AND ~~RE~~OPERABLE
CONDITION OR REMOVED
ENTIRELY BEFORE FINAL
DOCK APPROVAL IS GIVEN

You are hereby notified that no work shall be concealed upon these premises until the above violations are corrected. When corrections have been made, call for an inspection.

DATE

8/3

INSPECTOR

DO NOT REMOVE THIS TAG

TOWN OF SEWALL'S POINT

Building Department - Inspection Log

Date of Inspection: Mon Wed Fri 8/3, 2005 Page 1 of

PERMIT	OWNER/ADDRESS/CONTR	INSPECTION TYPE	RESULTS	NOTES/COMMENTS
7691	THOMAS	DRY-IN	WILL	RESCHEDULE
3	10 PALM ROAD FEAZEL ROOFING			INSPECTOR <i>OM</i>
7536	BUONO	DRY-IN	FAIL	
10	106 N. SEWALL'S Pt TUTTLE ROOFING			INSPECTOR <i>OM</i>
7105	CARLTON	FINAL REMODEL KITCHEN & BATH	FAIL	
11	6 PERRIWINKLE CIRC GLENMARK HOMES			INSPECTOR <i>OM</i>
1888	GEISINGER	TREE	PASS	
17	8 CASTLE HILL	(TAM?)		INSPECTOR <i>OM</i>
7327	GREEN	FINAL ROOF	DUPLICATION	
7327	19 RIO VISTA DR PACIFIC ROOFING			INSPECTOR
7308	ROMBERG	FINAL DOCK REPAIR	FAIL	
9	103 N. SEWALL'S Pt CUSTOM DECKS			INSPECTOR <i>OM</i>
7683	GALINIS	RETAINING WALL	PASS	CLOSE
7	26 S. SEWALL'S Pt HAMMERHEAD MARINE			INSPECTOR <i>OM</i>

OTHER: _____

TOWN OF SEWALL'S POINT

Building Department - Inspection Log

Date of Inspection: Mon Wed ~~Thu~~ Thu 2-21, 2008 Page 1 of 1

PERMIT	OWNER/ADDRESS/CONTR	INSPECTION TYPE	RESULTS	NOTES/COMMENTS
8811	Gilbert 8 Mandalay Stuart Roof	Final rec'd Eng Nit letter	PASS	Close INSPECTOR <i>[Signature]</i>
8806	Shore 22 Emanta Medalist	ROUGH ELEC. tie down truss eng. framing	PASS PASS PASS	INSPECTOR <i>[Signature]</i>
1308	103 Sewalls	ROUGH ELEC Final check	PASS	Close INSPECTOR <i>[Signature]</i>
8826	Cayes 103 N Sewalls Jimmy Powell Elec	Final	PASS	Close INSPECTOR <i>[Signature]</i>
8825	Kelso 26 Rio Vista Sunco	consult.	OK	INSPECTOR
6634	Kelso 26 Rio Vista H. Door	Final- Garage door	PASS	Close INSPECTOR <i>[Signature]</i>
				INSPECTOR

OTHER: _____

7326

DEMO

MASTER PERMIT NO. _____

TOWN OF SEWALL'S POINT

Date 2/22/05

BUILDING PERMIT NO. 7326

Building to be erected for SPE #3 LLC Rothberg Type of Permit Demo House+Pool

Applied for by OCEAN GATE GIC (Contractor) Building Fee #60K x 9.60/1000 = 576.00

Subdivision GOVT LOT Lot PARCEL 2 Block _____ Radon Fee _____

Address 103 N. SEWALL'S PT ROAD Impact Fee _____

Type of structure SFR A/C Fee _____

Parcel Control Number: _____ Electrical Fee _____

3537410000000012070000 Plumbing Fee _____

Amount Paid 576.00 Check # 011278 Cash _____ Other Fees (_____) _____ Roofing Fee _____

Total Construction Cost \$ 60,000 TOTAL Fees 576.00

Signed [Signature]
Applicant

Signed [Signature]
Town Building Official

PERMIT

- BUILDING
- PLUMBING
- DOCK/BOAT LIFT
- SCREEN ENCLOSURE
- FILL
- TREE REMOVAL

- ELECTRICAL
- ROOFING
- DEMOLITION
- TEMPORARY STRUCTURE
- HURRICANE SHUTTERS
- STEMWALL

- MECHANICAL
- POOL/SPA/DECK
- FENCE
- GAS
- RENOVATION
- ADDITION

INSPECTIONS

- UNDERGROUND PLUMBING _____
- UNDERGROUND MECHANICAL _____
- STEMWALL FOOTING _____
- SLAB _____
- ROOF SHEATHING _____
- TRUSS ENG/WINDOW/DOOR BUCKS _____
- ROOF TIN TAG/METAL _____
- PLUMBING ROUGH-IN _____
- MECHANICAL ROUGH-IN _____
- FRAMING _____
- FINAL PLUMBING _____
- FINAL MECHANICAL _____
- FINAL ROOF _____

- UNDERGROUND GAS _____
- UNDERGROUND ELECTRICAL _____
- FOOTING _____
- TIE BEAM/COLUMNS _____
- WALL SHEATHING _____
- LATH _____
- ROOF-IN-PROGRESS _____
- ELECTRICAL ROUGH-IN _____
- GAS ROUGH-IN _____
- EARLY POWER RELEASE _____
- FINAL ELECTRICAL _____
- FINAL GAS _____
- BUILDING FINAL _____

FEB 15 2005 21 18 FROM SENGENT
FEB 17 2005
Feb 16 2005 3 43PM
BY:

5614170665

TO 772+283+1538

P 003

No. 1296 P 3

Town of Sewall's Point BUILDING PERMIT APPLICATION

Permit Number _____

Date: 2-16-05

OWNER/TITLEHOLDER NAME SPE #3, LLC Phone (Day) _____ (Fax) _____

Job Site Address 103 N. Sewall's Point Rd City Sewall's Point State FL Zip _____

Legal Desc. Property (Subd/Lot/Block) _____ Parcel Number _____

Owner Address (if different): 7551 Isla Verde Way City Delray Beach State FL Zip 33446

Description of Work To Be Done Demolition of Main House, Pool and Deck

WILL OWNER BE THE CONTRACTOR?:

YES NO

COST AND VALUES

Estimated Cost of Construction or Improvements \$ 60,000

(Notice of Commencement needed over \$2500)

Estimated Fair Market Value prior to improvement \$ _____

Is Improvement cost 50% or more of Fair Market Value? YES NO

Method of Determining Fair Market Value, _____

(If no fill out the Contractor & Subcontractor sections below)

(If yes, Owner Builder Affidavit must accompany application)

CONTRACTOR/Company Ocean Gate General Contractor's Phone 772-283-6744 Fax 772-283-1598

Street 2854 SE Federal Hwy. City Stuart State FL Zip 34994

State Registration Number CBC062839 State Certification Number L04062100822 Martin County License Number 1981-512790

SUBCONTRACTOR INFORMATION

Electrical Jim Reisner Electrical, LLC State FL License Number EC-0002442

Mechanical _____ State _____ License Number _____

Plumbing _____ State _____ License Number _____

Roofing _____ State _____ License Number _____

ARCHITECT N/A Lic # _____ Phone Number _____

Street _____ City _____ State _____ Zip _____

ENGINEER N/A Lic # _____ Phone Number _____

Street _____ City _____ State _____ Zip _____

AREA SQUARE FOOTAGE - SEWER - ELECTRIC Living _____ Garage _____ Covered Patios _____ Screened Porch _____

Carport _____ Total Under Roof _____ Wood Deck _____ Accessory Building _____

I understand that a separate permit from the Town may be required for ELECTRICAL PLUMBING MECHANICAL, SIGNS POOLS WELLS, FURNACE BOILERS, HEATERS TANKS DOCKS SEA WALLS ACCESSORY BUILDING SAND OR FILL ADDITION OR REMOVAL AND TREE REMOVAL AND RELOCATIONS

CODE EDITIONS IN EFFECT AT TIME OF APPLICATION, Florida Building Code (Structural, Mechanical, Plumbing, Gas) 2001
National Electrical Code 2002 Florida Energy Code: 2001 Florida Accessibility Code 2001

I HEREBY CERTIFY THAT THE INFORMATION I HAVE FURNISHED ON THIS APPLICATION IS TRUE AND CORRECT TO THE BEST OF MY KNOWLEDGE AND I AGREE TO COMPLY WITH ALL APPLICABLE CODES, LAWS AND ORDINANCES DURING THE BUILDING PROCESS

OWNER OR AGENT SIGNATURE (required)

Patricia Valdez

State of Florida, County of Palm Beach

This the 16 day of Feb, 2005

by _____ who is personally known to me or produced

as identification Patricia Valdez

Notary Public

My Commission Expires _____

CONTRACTOR SIGNATURE (required)

Mark MacDonald

On State of Florida, County of Martin

This the 17 day of Feb, 2005

by MARK MACDONALD who is personally known to me or produced

as identification Kevin Tame

My Commission Expires _____

Atlantic Bonding Co., Inc.
Bonds Thru
Expires Apr 07, 2008
Commission #DD308192

PERMIT APPLICATIONS VALID 30 DAYS FROM ISSUANCE
Expires Apr 07, 2008
Bonds Thru
Atlantic Bonding Co., Inc.

TO BE COMPLETED WHEN CONSTRUCTION VALUE EXCEEDS \$2500.00

PERMIT # Applied For

TAX FOLIO # 35-3741-00-000-00120-7

NOTICE OF COMMENCEMENT

STATE OF Florida

COUNTY OF Martin

THE UNDERSIGNED HEREBY GIVES NOTICE THAT IMPROVEMENT WILL BE MADE TO CERTAIN REAL PROPERTY, AND IN ACCORDANCE WITH CHAPTER 713, FLORIDA STATUTES. THE FOLLOWING INFORMATION IS PROVIDED IN THIS NOTICE OF COMMENCEMENT.

LEGAL DESCRIPTION OF PROPERTY (INCLUDE STREET ADDRESS IF AVAILABLE):

103 North Sawall's Point Road, Sawall's Point, FL 34996

Part of GCV Lot 2 Sec 35 T37S
R4/E; (cont) AT PE of N/LN of S04E
R/W Sawall's Point Road, Seig ALG R/W

GENERAL DESCRIPTION OF IMPROVEMENT: Demolition of damaged home

OWNER: Michael Rothberg

ADDRESS: 7551 Isla Verde Way Delray Beach, FL 33446

PHONE # 561-289-8333

FAX # 561-865-3629

CONTRACTOR: Ocean Gate General Contractors, Inc.

ADDRESS: 2854 SE Federal Highway Stuart, FL 34994

PHONE # 772-283-6744

FAX # 772-283-1538

SURETY COMPANY (IF ANY) N/A

ADDRESS: STATE OF FLORIDA
MARTIN COUNTY

PHONE # THIS IS TO CERTIFY THAT THE
FOREGOING 1 PAGE(S) IS A TRUE
AND CORRECT COPY OF THE ORIGINAL

LENDER: N/A MARSHA EWING, CLERK

ADDRESS: BY [Signature]

PHONE # _____ DATE _____ FAX _____

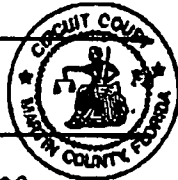

INSTR # 1816715
OR BK 01984 PG 2537
RECORDED 02/23/2005 12:32:57 PM
MARSHA EWING
CLERK OF MARTIN COUNTY FLORIDA
RECORDED BY T Copus (asst mgr)

PERSONS WITHIN THE STATE OF FLORIDA DESIGNATED BY OWNER UPON WHOM NOTICES OR OTHER DOCUMENTS MAY BE SERVED AS PROVIDED BY SECTION 713.13(1)(A)7, FLORIDA STATUTES:

NAME Mark MacDonald

ADDRESS: 2854 SE Federal Highway Stuart, FL 34994

PHONE # 772-283-6744

FAX # 772-283-1538

IN ADDITION TO HIMSELF, OWNER DESIGNATES Laurie Herter

OF Ocean Gate General Contractors RECEIVE A COPY OF THE LIENOR'S NOTICE AS PROVIDED IN SECTION 713.13(1)(B), FLORIDA STATUTES

PHONE # 772-283-6744

FAX # 772-283-1538

EXPIRATION DATE OF NOTICE OF COMMENCEMENT: February 21, 2006

THE EXPIRATION DATE IS ONE (1) YEAR FROM THE DATE OF RECORDING UNLESS A DIFFERENT DATE IS SPECIFIED ABOVE.

* [Signature]
SIGNATURE OF OWNER

February

SWORN TO AND SUBSCRIBED BEFORE ME THIS 21 DAY OF 2005

2005 BY _____

[Signature]
NOTARY SIGNATURE

OR PERSONALLY KNOWN
PRODUCED ID _____
TYPE OF ID _____



Patricia Valdez
Commission #DD308192
Expires: Apr 07, 2008
Bonded Thru
Atlantic Bonding Co., Inc

CERTIFICATE OF LIABILITY INSURANCE

DATE(MM/DD/YY)
02/18/2005

Producer Jack Rice Insurance
13080 S Belcher Road #H
Largo, FL 33773

Insured Modern Business Associates, Inc ET AL
L/C/F Ocean Gate General Contractors, Inc
9455 Koger Boulevard Suite 200
St Petersburg, FL 33702

THIS CERTIFICATE IS ISSUED AS A MATTER OF INFORMATION ONLY AND CONFERS NO RIGHTS UPON THE CERTIFICATE HOLDER THIS CERTIFICATE DOES NOT AMEND, EXTEND OR ALTER THE COVERAGE AFFORDED BY THE POLICIES BELOW

INSURERS AFFORDING COVERAGE

INSURER A Insurance Companies of the Americas
INSURER B
INSURER C
INSURER D
INSURER E

COVERAGES

THE POLICIES OF INSURANCE LISTED BELOW HAVE BEEN ISSUED TO THE INSURED NAMED ABOVE FOR THE POLICY PERIOD INDICATED NOTWITHSTANDING ANY REQUIREMENT TERM OR CONDITION OF ANY CONTRACT OR OTHER DOCUMENT WITH RESPECT TO WHICH THIS CERTIFICATE MAY BE ISSUED OR MAY PERTAIN THE INSURANCE AFFORDED BY THE POLICIES DESCRIBED HEREIN IS SUBJECT TO ALL THE TERMS EXCLUSIONS AND CONDITIONS OF SUCH POLICIES AGGREGATE LIMITS SHOWN MAY HAVE BEEN REDUCED BY PAID CLAIMS

INSH ITR	TYPE OF INSURANCE	POLICY NUMBER	POLICY EFFECTIVE DATE (MM/DD/YY)	POLICY EXPIRATION DATE (MM/DD/YY)	LIMITS
	GENERAL LIABILITY <input type="checkbox"/> COMMERCIAL GENERAL LIABILITY <input type="checkbox"/> CLAIMS MADE <input type="checkbox"/> OCCUR GEN'L AGGREGATE LIMIT APPLIES PER: <input type="checkbox"/> POLICY <input type="checkbox"/> PROJ-JECT <input type="checkbox"/> LOC				EACH OCCURRENCE \$ _____ FIRE DAMAGE (Any one fire) \$ _____ MED EXP (Any one person) \$ _____ PERSONAL & ADV INJURY \$ _____ GENERAL AGGREGATE \$ _____ PRODUCTS - COMP/OP AGG \$ _____
	AUTOMOBILE LIABILITY ANY AUTO ALL OWNED AUTOS SCHEDULED AUTOS HIRED AUTOS NON-OWNED AUTOS				COMBINED SINGLE LIMIT (Per accident) \$ _____ BODILY INJURY (Per person) \$ _____ BODILY INJURY (Per accident) \$ _____ PROPERTY DAMAGE (Per accident) \$ _____ AUTO ONLY - FA ACCIDENT \$ _____ OTHER THAN EA ACC \$ _____ AUTO ONLY AGG \$ _____
	GARAGE LIABILITY ANY AUTO				AUTO ONLY - FA ACCIDENT \$ _____ OTHER THAN EA ACC \$ _____ AUTO ONLY AGG \$ _____
	EXCESS LIABILITY <input type="checkbox"/> OCCUR <input type="checkbox"/> CLAIMS MADE DEDUCTIBLE RETENTION \$ _____				EACH OCCURRENCE \$ _____ AGGREGATE \$ _____ \$ _____ \$ _____
A	WORKERS COMPENSATION AND EMPLOYERS LIABILITY OTHER Client Code= 1425	WC61405010 101	1/1/2005	1/1/2006	<input checked="" type="checkbox"/> WC STATUTORY LIMITS <input type="checkbox"/> OTH-FR EI EACH ACCIDENT \$ 1,000,000 EL DISEASE - FA EMPLOYEE \$ 1,000,000 EL DISEASE - POLICY LIMIT \$ 1,000,000

DESCRIPTION OF OPERATIONS/LOCATION/VEHICLES/ EXCLUSIONS ADDED BY ENDORSEMENT / SPECIAL PROVISIONS
 Named Insured Modern Business Associates, Inc , Modern Business Associates II, Inc , Modern Business Associates III, Inc , Modern Business Associates IV, Inc , Modern Business Associates V, Inc
 Client address 2854 S E Federal Hwy Stuart, FL 34996

CERTIFICATE HOLDER	ADDITIONAL INSURED INSURER LETTER	CANCELLATION
Town of Sewall's Point Town Hall 1 South Sewall Point Road Sewall's Point, FL 34996		SHOULD ANY OF THE ABOVE DESCRIBED POLICIES BE CANCELLED BEFORE THE EXPIRATION DATE THEREOF THE ISSUING INSURER WILL ENDEAVOR TO MAIL 30 DAYS WRITTEN NOTICE TO THE CERTIFICATE HOLDER NAMED TO THE LEFT BUT FAILURE TO DO SO SHALL IMPOSE NO OBLIGATION OR LIABILITY OF ANY KIND UPON THE INSURER ITS AGENTS OR REPRESENTATIVES AUTHORIZED REPRESENTATIVE <i>Jack Rice</i>

Fax 772-283-1538

ACORD ™	CERTIFICATE OF LIABILITY INSURANCE	DATE (MM/DD/YYYY) FEB 18 05
PRODUCER ASSOCIATES AGENCY, INC PO BOX 16190 11308 N 53RD ST TEMPLE TERRACE FL 33687	THIS CERTIFICATE IS ISSUED AS A MATTER OF INFORMATION ONLY AND CONFERS NO RIGHTS UPON THE CERTIFICATE HOLDER THIS CERTIFICATE DOES NOT AMEND, EXTEND OR ALTER THE COVERAGE AFFORDED BY THE POLICIES BELOW	
INSURED OCEAN GATE BUILDERS, INC AND C/O OCEAN GATE GENERAL CONTRACTORS, INC 2854 S E FEDERAL HWY STUART FL 34994	INSURERS AFFORDING COVERAGE	NAIC #
	INSURER A SOUTHERN OWNERS INSURANCE CO	
	INSURER B AUTO OWNERS INSURANCE CO	
	INSURER C	
	INSURER D	
	INSURER E	

COVERAGES

THE POLICIES OF INSURANCE LISTED BELOW HAVE BEEN ISSUED TO THE INSURED NAMED ABOVE FOR THE POLICY PERIOD INDICATED NOTWITHSTANDING ANY REQUIREMENT TERM OR CONDITION OF ANY CONTRACT OR OTHER DOCUMENT WITH RESPECT TO WHICH THIS CERTIFICATE MAY BE ISSUED OR MAY PERTAIN THE INSURANCE AFFORDED BY THE POLICIES DESCRIBED HEREIN IS SUBJECT TO ALL THE TERMS EXCLUSIONS AND CONDITIONS OF SUCH POLICIES AGGREGATE LIMITS SHOWN MAY HAVE BEEN REDUCED BY PAID CLAIMS

INSR LTR	ADDL INSRD	TYPE OF INSURANCE	POLICY NUMBER	POLICY EFFECTIVE DATE (MM/DD/YY)	POLICY EXPIRATION DATE (MM/DD/YY)	LIMITS
A		GENERAL LIABILITY <input checked="" type="checkbox"/> COMMERCIAL GENERAL LIABILITY <input type="checkbox"/> CLAIMS MADE <input checked="" type="checkbox"/> OCCUR _____ GENI AGGREGATE LIMIT APPLIES PER <input type="checkbox"/> POLICY <input type="checkbox"/> PROJECT <input type="checkbox"/> LOC	20637299-034612	JUL 3 04	JUL 3 05	EACH OCCURRENCE \$ 1,000,000 DAMAGE TO RENTED PREMISES (Ea occurrence) \$ 50,000 MED EXP (Any one person) \$ 5,000 PERSONAL & ADV INJURY \$ 1,000,000 GENERAL AGGREGATE \$ 2,000,000 PRODUCTS-COMP/OP AGG \$ 2,000,000
		AUTOMOBILE LIABILITY <input checked="" type="checkbox"/> ANY AUTO <input type="checkbox"/> ALL OWNED AUTOS <input type="checkbox"/> SCHEDULED AUTOS <input checked="" type="checkbox"/> HIRED AUTOS <input checked="" type="checkbox"/> NON-OWNED AUTOS _____	44-560-167-00	JUL 3 04	JUL 3 05	COMBINED SINGLE LIMIT (Ea accident) \$ 1,000,000 BODILY INJURY (Per person) \$ BODILY INJURY (Per accident) \$ PROPERTY DAMAGE (Per accident) \$
		GARAGE LIABILITY <input type="checkbox"/> ANY AUTO				AUTO ONLY EA ACCIDENT \$ OTHER THAN AUTO ONLY EA ACC \$ AGG \$
B		EXCESS / UMBRELLA LIABILITY <input checked="" type="checkbox"/> OCCUR <input type="checkbox"/> CLAIMS MADE _____ DEDUCTIBLE <input checked="" type="checkbox"/> RETENTION \$ 10,000	44-560-167-01	JUL 3 04	JUL 3 05	EACH OCCURRENCE \$ 1,000,000 AGGREGATE \$ 1,000,000 \$ \$ \$
		WORKERS COMPENSATION AND EMPLOYERS LIABILITY ANY PROPRIETOR/PARTNER/EXECUTIVE OFFICER/MEMBER EXCLUDED? If yes describe under SPECIAL PROVISIONS below				WC STATUTORY LIMITS OTHER E L EACH ACCIDENT \$ E L DISEASE EA EMPLOYEE \$ E L DISEASE POLICY LIMIT \$
		OTHER				

DESCRIPTION OF OPERATIONS/LOCATIONS/VEHICLES/EXCLUSIONS ADDED BY ENDORSEMENT/SPECIAL PROVISIONS

CERTIFICATE HOLDER

CANCELLATION

TOWN OF SEWALL'S POINT BUILDING DEPARTMENT TOWN HALL ONE S SEWALL,S POINT RD SEWALL'S POINT, FL 34996 Attention	SHOULD ANY OF THE ABOVE DESCRIBED POLICIES BE CANCELLED BEFORE THE EXPIRATION DATE THEREOF THE ISSUING COMPANY WILL ENDEAVOR TO MAIL 10 DAYS WRITTEN NOTICE TO THE CERTIFICATE HOLDER NAMED TO THE LEFT BUT FAILURE TO DO SO SHALL IMPOSE NO OBLIGATION OR LIABILITY OF ANY KIND UPON THE INSURER ITS AGENTS OR REPRESENTATIVES AUTHORIZED REPRESENTATIVE  Jason Farquhar
---	---



**CITY OF STUART
OCCUPATIONAL LICENSE
2004-2005**

LICENSE NO	ACCOUNT NO	CATEGORY NO
4058	20308	061002

TAX YEAR BEGINS OCTOBER 1 AND ENDS SEPTEMBER 30
PAYMENT AFTER OCTOBER 1 CONSTITUTES VIOLATION
OF CITY CODE OF ORDINANCES

BUSINESS TYPE	CONTRACTOR - BUILDING
---------------	-----------------------

OWNER AND LOCATION	MARK D MACDONALD 2854 SE FEDERAL HW
--------------------	--

This occupational license does not permit the holder to operate in violation of any City law ordinance or regulation. Any changes in location or ownership must be approved by the City License Section, subject to zoning restrictions. This License does not constitute an endorsement approval or disapproval of the holder's skill or competence or of the compliance or non compliance of the holder with other laws regulations or standards.

STATE LICENSE NO CG-C062839

Occupational Licensing 772-288-5319

FEE	PENALTY	TRANSFER	MISCELLANEOUS	PAID
100 00	0 00	0 00	0 00	100 00

BUSINESS NAME AND MAILING ADDRESS	OCEAN GATE GENERAL CONTRACTORS MARK D MACDONALD 2854 SE FEDERAL HW STUART, FL 34994
-----------------------------------	--

DATE
10/13/2004

CHERYL WHITE
CITY CLERK



STATE OF FLORIDA

AC# 1457145

DEPARTMENT OF BUSINESS AND
PROFESSIONAL REGULATION

CGC062839 06/21/04 030736666

CERTIFIED GENERAL CONTRACTOR
MACDONALD, MARK DAVID
OCEAN GATE GENERAL CONTRACTORS IN

IS CERTIFIED under the provisions of Ch 489 vs
Expiration date AUG 31, 2006 L04062100822

TOWN OF SEWALL'S POINT

Building Department - Inspection Log

Date of Inspection: Mon Wed Fri APRIL 4, 2005 Page 1 of

PERMIT	OWNER/ADDRESS/CONTR	INSPECTION TYPE	RESULTS	NOTES/COMMENTS
7412	DONOHUE	GAS POUCE IN	PASS	
1A	1103 S. Sewall's Pt Van Sammens			INSPECTOR <i>OM</i>
7433	SCHRAEDER	FILL FINAL	PASS	
7	4 EMARITA WAY OIB			INSPECTOR <i>OM</i>
7321	KIRLINGER	Dry IN TTR	PASS	
2	143 S. River Rd SMART ROOFING	METAL		INSPECTOR <i>OM</i>
7306	R. MEE	FOOTER PERMAN		
1	29 S. RIVER RD LEAK DEVEL	(FIRST PLEASE)		INSPECTOR
7349	MAUD	ELEC SVC CHG	FAIL	
10	21 N. RIVER RD KRAUSS + CRANE	FINAL?		\$40 FEE INSPECTOR <i>OM</i>
7326	ROTHBERG	FINAL DEMO	PASS	CLOSE
11	103 N. SEWALL'S PT OCEAN GATE			INSPECTOR <i>OM</i>
7272	Male Trends	Final Drywall,	PASS	
9	3866 E. Ocean Blvd Wayne Kirchman Contr	Ceiling + Light Fixtures (Electric)	PASS	INSPECTOR <i>OM</i>
OTHER:				
10	CASTLE HILL	WORK IN PROGRESS?		
8		HAS STOP WORK ORDER		

CORREPPONDENCE

BLUE WATER MARINE CONSTRUCTION, INC.

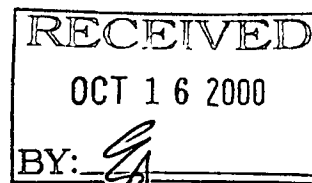

FILE

October 11, 2000

Mr Ed Arnold
Town of Sewalls Point Building Department
1 South Sewalls Point Road
Sewalls Point, Florida 34996

RE: Withdrawal of Permit for Mr. Henry Rothberg

Dear Mr Arnold

*APPL SUBMITTED 2/8/2000!
DOCUMENTS VOIDED & DISCARDED.*

As reflected in the enclosed letter sent to Mr Rothberg, Blue Water Marine Construction, Inc is withdrawing the permit as applied for to install riprap located at 103 North Sewalls Point Road Blue Water Marine Construction will have no further interest in this project

Most Sincerely,

Mark T Diekman

Enclosures

CC Henry Rothberg
Stephen Brown, Surveyor

SPEED MESSAGE

TO

BLUE WATER MARINE
FAX 561 286 1260
ATT MARK

FROM

HENRY M. ROTHBERG
103 N. SEWALLS POINT RD
SEWALLS POINT, FL. 34996

SUBJECT

SEA WALL WORK AT 103 N. SEWALLS POINT RD. SEWALLS POINT FL

DATE

OCT 10, 2000

FOR MORE THAN 4 MONTHS I HAVE HAD NO
REPLY TO MY TELEPHONE AND FAX MESSAGES TO YOU
AND SINCE I GAVE YOU A \$1,000 ADVANCE
AND WORK TO BE DONE - AND SINCE NO WORK
HAS BEEN DONE ON THE SITE -

THIS LETTER IS TO TERMINATE YOUR COMPANY
AS THE CONTRACTOR. AND TO ASK FOR RETURN
OF MY \$1,000 ADVANCE. SINCE NO WORK HAS
YET STARTED ON THE SITE -

YOUR COMPANY IS DISCHARGED FROM THIS
PROJECT

MY PRESENT PLAN IS UNTIL THE
END OF OCT, 2000 IS 520-203 4004

Fax 520-203 4005

SIGNED

Henry M. Rothberg

Wilson Jones

WHITE - ORIGINAL

CANARY - DUPLICATE

44-900 • DtmRcs.r

Carbonless Copy-A-Way Form 8190 ATCO USA, Inc.

BLUE WATER MARINE CONSTRUCTION, INC.

October 11, 2000

Henry M Rothberg
103 North Sewalls Point Road
Sewalls Point, Florida 34996

Sent via facimile & Certified Mail

RE: Termination of Contract and Permit

Dear Mr Rothberg

We received your faxed Speed Message dated October 10, 2000 regarding terminating our contract and requesting a refund of your deposit

No work has been started at your residence because we do not have a permit from the Sewalls Point Building Department to proceed As you are aware, a special waterline survey has been required from Ed Arnold of Sewalls Point Building Dept and, after that, attendance at the Town Hall Meeting once the survey has been received from the surveyor

We cannot refund any of the deposit We paid the \$500 00 Department of Environmental Protection application fee for you and paid \$ 150 00 for engineered drawings sealed by a Certified Engineer, not to mention our time invested and those items listed on the enclosed rate sheet We have already expended more money than what the deposit will cover

We do tend to agree that it should not take this long to obtain a local permit Therefore, we are withdrawing the permit application from the Sewalls Point Building Department and notifying Mr Arnold of our intentions

Best Regards,



Mark T Diekman
President

Enclosures

CC Ed Arnold, Sewalls Point Building Department
Stephen J Brown, Inc Surveyors

BLUE WATER MARINE CONSTRUCTION, INC.

MINIMUM CHARGE FOR RESIDENTIAL PERMIT IS \$500 00 WHICH INCLUDES

- (1) Drawings
- (2) Documents/Application Completion
- (3) Photo Copying
- (3) Notary Service
- (5) Recording of Notice of Commencement
- (6) Telephone and mail expenses
- (7) Pick up and delivery to building department
- (8) Correspondence with agencies

NOT included in base charge above is

- (1) Engineering fees
- (2) Surveying fees
- (3) State and local permit fees
- (4) Recording fees

A separate charge of \$45 00 will be ADDED for

- (1) Submissions to a homeowner's association, architectural review committee, or engineering firms representing an association or individual

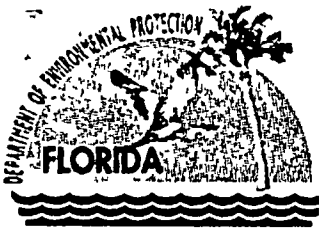

Department of Environmental Protection

Jeb Bush
Governor

Southeast District
P O Box 15425
West Palm Beach, Florida 33416

David B Struhs
Secretary

April 10, 2000

Remittance: 379304
DDN/PNR:

Blue Water Marine Construction
3558 S.E. Dixie Highway
Stuart FL 34997

RE: Receipt Number 314347

Dear Sir/Madam:

Rothberg, Henry M.
165717-001

Your remittance, check number 20100 for \$500.00, was received by the Department of Environmental Protection on April 3, 2000.

Sincerely,

Margarita C. Gomez
Margarita C. Gomez, Senior Clerk
Department of Environmental Protection

Transmittal: 15119
Deposit:

CRAR009/

TOWN OF SEWALL'S POINT:

PERMIT APPLICATION SUBMITTAL LOG

FEBRUARY 2000 SHEET 1 OF 2

DATE	PROJECT ADDRESS	OWNER	CONTRACTOR	PERMIT TYPE		REVIEW			APPLICATION		NOTES/COMMENTS	PERMIT	
				BLDG	MISC	1ST	2ND	3RD	DENY	APPR		ISSUED	P N
2/1	1 W HIGH POINT	HOGAN	CARDINAL RFG		PERCOF	2/4					ADD'L SUBM - YEE 1/24	NA	N/A
2/2	110 N. S.P. RD.	JORDAN	O/B		T/R	2/4					FIELD INSP. SCHED. 2/7/00		
2/3	4 OAK HILL WAY	CONWAY	CONWAY CONST.	SFR		2/4	2/8	3/3		3/3			4857
2/3	24 SIMARA	McKINNEY	O/B	PORT ENCL.		2/4	2/9			2/21	2/24 ADD'L BLDG RFG RECD	3/2	4851 ✓
2/3	4 PALAMA WAY	PERROW	QUALITY FENCE		FENCE (EXT)	2/15				2/15		2/16	4830 ✓
2/3	106 N. S.P. RD.	BUONO	RHR POOLS		SPA (ADD'L POOL)								4822
2/3	855. S.P. RD.	DOSS	ACCURATE ELECT.		SERV CHG.	2/4				2/4		2/4	4818
2/3	11 W. HIGH POINT	CLEMENTS	JENKINS LANDSCAPE		T/R (LOCATE)	2/4	2/7			2/7	FIELD INSP. SCHED 2/7/00	3/15	0302
2/4	20 CASTLE HILL WAY	OSBORNE/LOWE	BUFORD CONST. INC	SFR		3/3	3/24	3/30		3/30	APPL SUBM 3/27	4/3	4877 ✓
2/4	2 PALMETTO	BARILE	EAST COAST ALUM.		REFLT.	2/4				2/4		2/11	4827
2/4	66 N. S.P. RD	MIRAGLIA	LEE HAYMES		T/R	2/4				2/4	FIELD INSP 2/4; D.E.R REQ	2/4	293
2/4	126 N. S.P. RD.	CICORIA	O/B		ENTRY WALL	2/4				2/4		2/7	4821
2/7	22 SIMARRA	RAAS	O/B		FENCE	2/4				2/4		2/7	4819
2/7	7 KINGSTON CT.	CARLSON	GLEN HUTCHINS	ADDN		2/28	3/8			3/8		3/8	4861
2/8	2 PERIWINKLE	BERGALIS	ROBI. DEAN SCHILLER		DECK (REP)	2/11				2/11		5/2	4905 ✓
2/8	17 PERIWINKLE	O'DONNELL	QUALITY FENCE		FENCE	2/16				2/16		2/16	4831 ✓
2/8	11 CASTLE HILL WAY	HEURIEGEL	ADVANTAGE POOLS		POOL/PATIO	2/21	3/3			3/3	REV/RESUB (SETBACK VIO)	3/7	4856 ✓
2/8	160 S. RIVER RD.	MADDER	FENCE CRAFTERS		FENCE			2/18	(OWNER)		APPL. WITHDRAWN		
2/8	29 S. RIVER RD.	RIMER	ATKINSON		DEM.	2/9				2/9	MATH HOUSE, D/W WALK	2/11	4826
2/8	103 N. SEOWALL RD	ROTHBERG	PIPEWATER WARE		RIPAP	2/18	2/4				APPL SUB 2/3/00		
2/11	580 SE OCEAN BLVD	COMM'L MGMT "CHICO'S"	*	COMM'L ALT		2/15				2/15	* NONE - SUBMITTED BY ARCHITECT		
2/14	140 VIA LUCINDIA	GIGANTE	JIM'S RFG		PEROOF	2/15				2/15		2/18	4838
2/14	17 NE LOFTING WAY	CONWAY	OLYMPIC POOLS		POOL/SPA	3/2				3/2		3/2	4853

RTU TO ARCH.

TOWN OF SEWALL'S POINT, FLORIDA

Date FEBRUARY 22 ~~16~~ 2005 TREE REMOVAL PERMIT No 2423

APPLIED FOR BY SPE #344C (DORLBERG) (Contractor or Owner)

Owner 103 N. Sewall's Point Rd

Sub-division _____, Lot _____, Block _____

Kind of Trees _____

No Of Trees REMOVE per attached

No Of Trees RELOCATE _____ WITHIN 30 DAYS (NO FEE)

No Of Trees REPLACE _____ WITHIN 30 DAYS

REMARKS _____

_____ FEE \$ \$15.00

Signed, _____ Applicant Signed, Gene Summerville (GMS) Town Clerk

TOWN OF SEWALL'S POINT

Call 287-2455 - 8:00 A.M.-12:00 Noon for Inspection
WORK HOURS 8:00 A.M. - 5:00 P.M. - NO SUNDAY WORK

TREE REMOVAL PERMIT

RE ORDINANCE 103

[Large empty rectangular box for notes or drawing]

PROJECT DESCRIPTION _____

REMARKS _____

Feb 18 2005 10 57AM

No 7364 P 3/3

TOWN OF SEWALL'S POINT APPLICATION FOR TREE REMOVAL, RELOCATION, REPLACEMENT

Tree Defined: Any self-supporting, woody plant which normally grows to an overall height of at least fifteen (15) feet in the vicinity of the town. Replant and landscape trees shall be considered a tree

No permit required for:

- 1 Trimming of trees unless it effectively removes it, meaning trimming or pruning to the extent that a plant's natural function is severely altered.
- 2 Trees with a diameter of less than two inches.

Permit Fee:

- 1 Tree permits are \$15 00, payable in advance
- 2 No permit fee needed for tree which is dead, diseased, injured, hazardous to life or property, or a prohibited species. Prohibitive species include Earleaf Acacia, Woman's Tongue, Norfolk Island Pine, Bischofia, Schefflera, Ear Tree, Eucalyptus, Non-Native Ficus, Silk Oak, Chinese Tallow Tree, Java Plum, Chinaberry, Brazilian Peppers, Australian Pine, and Melaleuca and must be removed before construction begins on new single family residence (S F R)

No removal permits will be issued for native species trees: Black Ironwood, Black Mangrove, Blolly, Burtonwood, Cabbage Palm, Cocoplum (red tip and green tip), Coral Bean, Deer Moss, Gray Twig, Gopher Apple, Gumbo Limbo, Inkwood, Laurel Oak, Leather Fern, Live Oak, Mahogany, Marlberry, Mastic, Mulberry, Myrtle Oak, Paradise Tree, Pigeon Plum, Pond Apple, Prickly Pear, Red Mangrove, Red Maple, Red bay, Saffron Plum, Sand Pine, Scrub Pine, Satinleaf, Saw Palmetto, Scrub Hickory, Sea Grape, Sea Oxeye Slash Pine Stoppers, Wild Lime, Sumac (southern), Sugar Berry (Hackberry), Torchwood, Wild Coffee, Varnish Leaf, Water Oak, Wax Myrtle, West Indian Cherry White Mangrove

Application procedures:

- 1 Fill out application information below to include
 - a applicant information
 - b written statement giving reasons for removal, relocation, or replacement if necessary
 - c for a new S.F.R., a site plan which shall include the dimensional location on a survey, scale drawing or aerial photograph, superimposed with lot lines of scale, of all existing or proposed structures, improvements and site uses, location of affected trees identified with an estimated size and number, etc
 - d for an existing residence, a drawing of house with location of trees to be removed, relocated can be submitted in lieu of site plan
- 2. Place identification tape or ribbon on each tree for clarity to inspector if necessary
- 3. Inspector will visit site and review application and pass, fail or revise.
- 4. Permit must be picked up and on site prior to work proceeding
- 5. Permits expire if work does not begin within 3 months and if activity is interrupted over 45 days.

Owner SPE #3 LLC **Address** 103 N. Sewall's Point **Phone** _____

Contractor Ocean Gate G.C. **Address** 2854 SE Federal Hwy **Phone** 772-283-6744

No. of Trees: REMOVE _____ **Type** _____

No. of Trees: RELOCATE _____ **WITHIN 30 DAYS** **Type** _____

No. of Trees: REPLACE _____ **WITHIN 30 DAYS** **Type** _____

Written statement giving reasons: Trees will be in the way and damaged during demolition
of house.

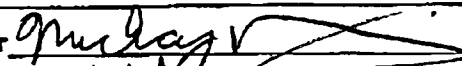
* **Signature of Property Owner**  **Date** 2/18/05

Approved by Building Inspector  **Date** 2/22 **Fee:** 1500

Plans approved as submitted _____ **Plans approved as revised/marked** /

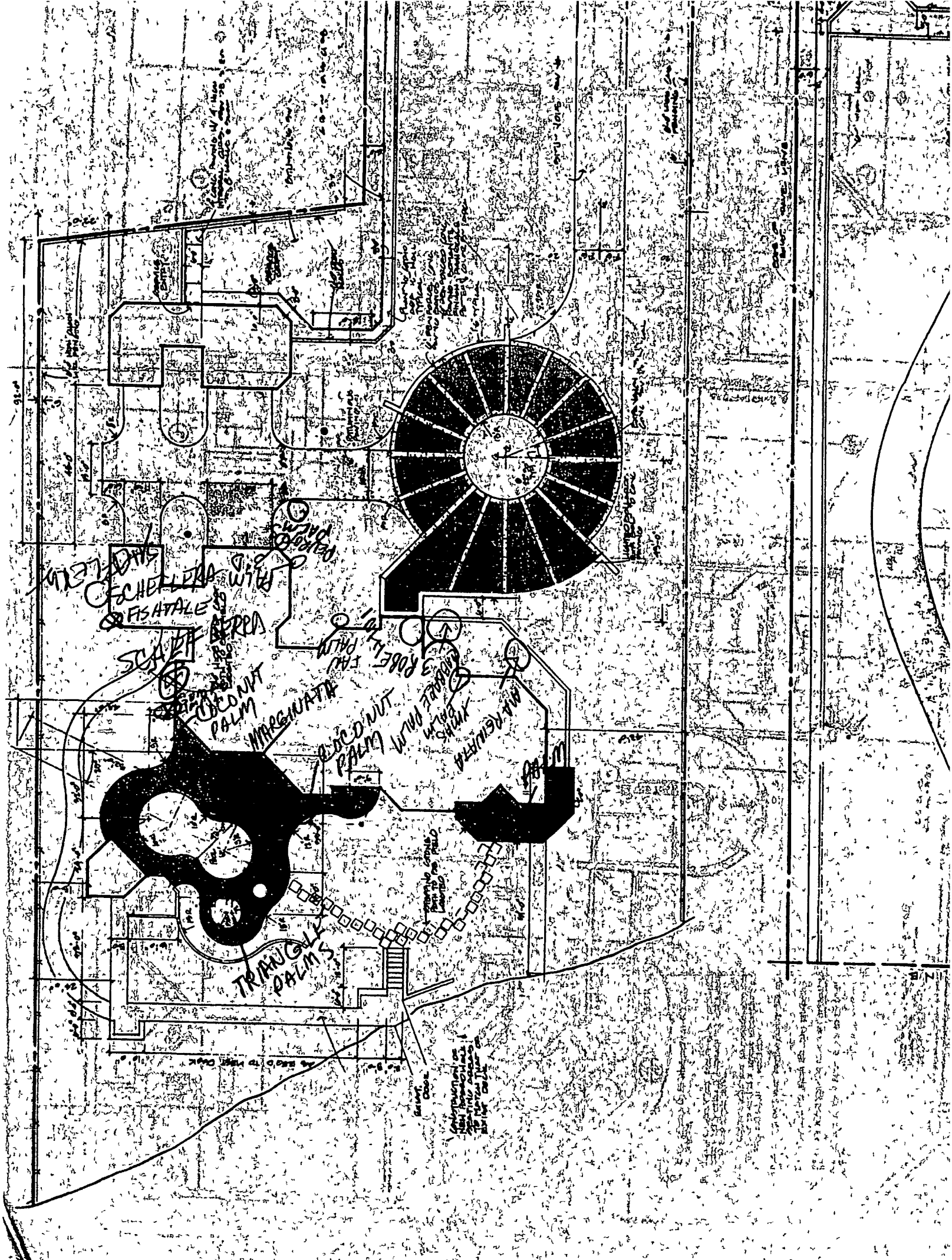

SCHELLER WITH
FISATALE

SCAFF
BEREA

COCONUT
PALM

MARGUATE

COCONUT
PALM

WIND
ROBEE
PALM

MARGUATE
PALM

TRUJILLO
PALM

TRUJILLO
PALM

TRUJILLO
PALM

